



# CEC

## GUIDE TO ESTIMATING

**GENERAL  
INFORMATION**



**INDUSTRY  
DEFINITIONS**



**SPECIAL  
PRECAUTIONS**



**LABOR  
PROCEDURES**



**MOLDINGS, STRIPE  
TAPE & DRILL TIMES**



**REFINISHING  
PROCEDURES**



**MOTOR**

Collision Estimating Data



**1-800-4A-MOTOR  
(1-800-426-6867)**

**Text Explanation Guide**

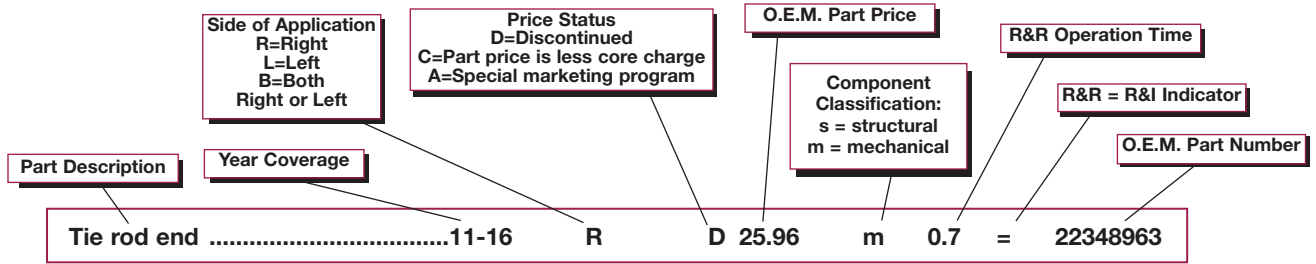

**Primary Group Heading**

**Illustrated Part Call-Out Number**

**R&I Operations**

**Paint Operation Time**

**Footnote Symbol & Definition**

**Additional Refinishing Information**

**Basic Sub-Group**

**Manufacturer's Special Marketing Designation**  
(see "PARTS PRICES"- General Information page)

**R&R = R&I Indicator**  
(see "R&I (Remove & Reinstall)" - Industry Definition page)

**Drilling Operation Time**

**QUARTER PANEL**

**REFINISHING NOTES**  
Add for stone guard if required. See Guide to Estimating.

**Refn quarter panel exterior surface only**

11-16	p1.7
edges & pockets	11-16 p.3
lock pillar	11-16 p.5

**OVERLAP OPERATIONS**

R&R quarter panel with roof off deduct

11-16 B	4.0
---------	-----

**R&I OPERATIONS**

R&I trim panel

11-16 B	0.4
---------	-----

**SECTIONING OPERATIONS**

Sctn qtr panel cut in window opening

11-16 R	p2.5	11.0
11-16 L	p2.5	11.5

**PARTS AND R&R OPERATIONS**

QUARTER PANEL & COMPONENTS					
1	Outer panel ... (p.2.5)	11-16 R	199.98	14.0	75142 8990
	(p.2.5)	11-16 L	199.98	14.5	75144 1000
2	Lower pillar (p.5)	11-16 R	54.48	3.5	75143 4360
	(p.5)	11-16 L	54.48	3.5	75143 4370
3	Fuel door (p.5)	11-16	17.00	0.3	= 75760 1050
<b>Belt Molding</b>					
4	at window	11-16 R	33.25	0.3	= 79106 7000
		11-16 L	33.42	0.3	= 79106 7010
<b>Molding</b>					
5	rear vertical	11-16 RA	23.03	0.3	= 79104 7800
		11-16 LA	23.03	0.3	= 79104 7810
6	Body side mldg	11-16 R	37.00 #	0.3	79116 1360
		11-16 L	37.63 #	0.3	79116 1370
7	Wheel opng mldg (d.2)	11-16 R	53.80	0.3	= 79116 5080
	(d.2)	11-16 L	53.80	0.3	= 79116 5090

# PARTS: Order by model & color.  
† LABOR: Time includes R&I quarter glass.

Operation times reported herein are compiled from available manufacturer data, as well as our own evaluation of shop data and are published only as an estimating guide.

This Guide to Estimating provides the guidelines that apply to MOTOR Crash Estimating Data. Knowledge and application of these guidelines will assist the estimator in developing a clear estimate, reflecting as accurately as possible the requirements to perform operations listed. To maintain accuracy, estimators must frequently refer to these pages throughout the estimating process.

## BOLTED-ON PARTS

The phrase "BOLTED-ON PARTS" referenced in this publication refers to mechanically fastened components that are directly attached to the component that is being replaced and includes braces, brackets, mounts, shields, extensions, interior trim, etc. Mechanical fasteners may include bolts, nuts, screws, clips and rivets.

## ESTIMATING SEQUENCE

Listed under each basic assembly are the related and component parts. List the damage according to the basic assembly, taking the basic item first. Then, starting from the outside of the vehicle and working inward, list everything attached to it which is damaged. By following this procedure, you will make a more thorough inspection.

For instance, on an estimate involving front fender damage, inspect as shown:

- Fender
- molding
- nameplate
- emblem
- Fender Liner

## FOOTNOTES

Footnotes are used to present information specific to the indicated component or operation. Footnotes are not intended to be used in place of service repair information.

## PART PRICES

Prices used in MOTOR Crash Estimating Data are factory suggested list prices, as supplied to us by the manufacturer. Dealers may not be required to sell at this price and may be free to determine their own prices. When a price is prefixed by the letter "D" it indicates that this part has been discontinued by the manufacturer and for your convenience, we continue to publish the last available price. When a part is prefixed by the letter "C," this indicates a core value assigned by the manufacturer has been deducted from the manufacturer's suggested retail price. When a price is prefixed by the letter "A," it indicates a Special Marketing Program part.

**General Motors Target Marketing Program:** This program has been discontinued by GM. Parts indicated with the letter "A" represent components included in the program. These parts do not have a suggested list price supplied by General Motors. The price shown following the letter "A" is an approximation which you may find helpful. These prices are to be regarded as a GUIDE only. The actual price, which may be higher or lower than the published price, can be determined by contacting the General Motors dealer in your area.

**Mopar Competitive Crash Parts Program:** The prices for these parts may carry a special discount. Actual price should be determined by calling the dealer in your local area. Dealers are not required to participate in this program and are free to determine their own prices for these parts.

## PART PRICES - Continued

Part prices do not include cost of state and local taxes, bolts, rivets, screws, nuts, washers, clips, fasteners, paint/body repair materials and refinishing unless otherwise noted.

## PART QUANTITIES

Many procedures require replacement of parts such as fasteners (bolts, rivets, screws, nuts, clips, for example) or washers. The applicable quantities for these parts are provided whenever possible. This information will be provided as reported by the OEM.

## TECHNICAL INFORMATION

Labor times shown in reference to labor procedures contained in Tech-Cor Bulletins are researched and developed by MOTOR. While Tech-Cor Bulletins are protected under copyright laws, reproduction of these bulletins is permitted as long as the bulletin is reproduced in its entirety, including source attribution.

Tech-Cor, LLC.  
Technical Research Dept.  
110 East Palatine Road  
Wheeling, Illinois 60090  
Phone: (847) 667-2340  
<http://www.tech-cor.net>

## I-CAR

Created by the collision industry in 1979, I-CAR, the Inter-Industry Conference on Auto Collision Repair, conducts extensive collision repair research to develop and deliver quality technical educational programs to professionals in the insurance and collision repair industries, which increases the common understanding of required repair methods. The international not-for-profit training organization works toward its vision that every person in the collision industry has the necessary technical knowledge and skills relevant to their position to achieve a complete and safe repair. Ultimately benefiting the vehicle owner, information on I-CAR training is available at <http://www.i-car.com>.

## NASTF

The National Automotive Service Task Force is a not-for-profit, no-dues task force established to facilitate the identification and correction of gaps in the availability and accessibility of automotive service information, service training, diagnostic tools and equipment and communications for the benefit of automotive service professionals. NASTF is a voluntary, cooperative effort among the automotive service industry, the equipment and tool industry and automotive manufacturers. See their website <http://www.nastf.org> for information on NASTF programs and activities.

## ASA

The Automotive Service Association (ASA) advances professionalism and excellence in the automotive repair industry through education, representation and member services. See their website <http://www.asashop.org> for information on ASA's programs and activities, or if you have any questions about membership, please call the ASA Membership Services Department at (800) ASA-SHOP, ext. 295, or send e-mail to [asainfo@asashop.org](mailto:asainfo@asashop.org).

## TECHNICAL INFORMATION - Continued

### ASE

The National Institute for Automotive Service Excellence (ASE) was established in 1972. ASE's mission is to improve the quality of vehicle repair and service through the testing and certification of repair and service professionals. See their website <http://www.ase.com/> for information on ASE's programs and activities or e-mail to [webmaster@asecert.org](mailto:webmaster@asecert.org).

### AGRSS99

The Automotive Glass Replacement Safety Standards (AGRSS99) Council, Inc. is a not-for-profit organization dedicated to the safe replacement of auto glass. Stationary (bonded) auto glass replacement is important in maintaining the structural integrity and safety features of the vehicle. The AGRSS99 Standard: ANSI 002-2002 is the North American standard detailing the steps and procedures to provide safer automotive glass replacement. See their website <http://www.agrss.com> for information on AGRSS99 programs and activities.

## UNDERHOOD DIAGRAMS

MOTOR includes underhood diagrams when available. All measurements are in millimeters. Please refer to MOTOR "Collision Repair Data" manual or MOTOR E-Frame Data on CD for complete vehicle dimension specifications. All underhood illustrations used herein are copyrighted by Hein-Werner Corporation, Milwaukee, Wisconsin and used with the permission of the copyright owner.

## ADD IF REQUIRED

MOTOR Collision Estimating Data is based on the base model vehicle configuration, standard or regular production options, and/or standard replacement operations. "Add if required" operations are for extra procedures necessitated by optional factory equipment or certain collision scenarios that may be encountered. "Add if required" operations should be added to the estimate whenever applicable after an "on the spot" inspection of vehicle damage and/or vehicle options.

## COMPONENT CLASSIFICATION

The purpose of classifying components is to describe physical properties of the component, and classifications may inform the estimator that specialized technician skill levels and/or tools may be required. Indicators are not intended to determine labor rates charged, or to be inclusive of all components. Any additional component classification(s) should be determined after an on-the-spot evaluation of required repair procedures.

### CLASSIFICATION INDICATORS ARE PROVIDED FOR YOUR CONVENIENCE AND MUST ONLY BE CONSIDERED A HELPFUL GUIDE.

MOTOR component classifications are defined as follows:

**(M) Mechanical:** Components that transform one form of motion or energy into another. Mechanical components would likely be serviced at a mechanical service facility rather than a body repair facility if that component failed during normal operation. Mechanical components will likely require a specialized technician skill level and/or specialized tools.

**(S) Structural:** Components that provide a load bearing foundation for the purpose of safety and/or stability

**(no classification) Body:** Components that do not fall under the mechanical or structural classification

## D&R (Disconnect & Reconnect)

Some labor procedures require disconnecting (unplug and/or unbolt) of a component/assembly at the point where it is attached to the subject part. The component assembly is not completely removed from the vehicle. The component is reconnected during the assembly procedure. Due to various configurations and type of parts that may be involved in the D&R operations and considering that the times involved are generally not definable in tenths of hours, time for D&R is not provided. When D&R is necessary to perform a labor operation, it is included in that labor operation's time.

## FRAME MACHINE SET-UP

Due to the different types of frame machines used in the collision repair industry, labor times for frame machine set-up are not developed by MOTOR, nor otherwise included in any operation. Each frame machine manufacturer may have its own unique configurations and setup processes. For example, some machines are of a "drive-on" type while others are of a "dedicated bench" type, and there are procedural differences between the two set-up methods. Additionally, there may be variables unique to the actual vehicle that may increase or decrease frame machine set-up time. MOTOR suggests using an on-the-spot evaluation to determine an appropriate frame machine set-up time.

## INCLUDED and/or NOT INCLUDED LABOR OPERATIONS

### INCLUDED OPERATIONS:

When items or operations appear in the Guide to Estimating pages under the "Included" heading it means that the operation is performed in conjunction with another operation. For example, Steering Wheel R&I is an individual operation, but when replacing a steering column, steering wheel R&I is also performed and therefore included in Steering Column R&R.

If an item is listed without a qualifier, it means all labor has been considered within the indicated labor procedure. If a specific qualifier (such as R&I) appears, it means only the specified qualifier applies.

### NOT INCLUDED OPERATIONS:

Items or operations listed under "Does Not Include" were not considered in the development of published labor operation times. These operations may or may not be required depending upon the vehicle or repair process used. If any of these items or operations are required, they should be considered by the estimator. If a specific qualifier (such as R&I) appears, it means only the specified qualifier applies.

## NAGS - GLASS PRICES

Glass Prices: We include, when available, both the vehicle manufacturer and the NAGS benchmark prices as applicable to each make and model. All NAGS part numbers and benchmark prices are provided from National Auto Glass Specifications, a division of Mitchell International, Inc. Labor operation times listed on the line with the NAGS information are MOTOR suggested labor operation times; NAGS labor operation times are not included.

## OEM (Original Equipment Manufacturer)

Used to define original vehicle manufacturer.

## OVERHAUL

Remove an assembly from the vehicle, disassemble, clean, inspect, replace parts as needed, reassemble, install and adjust (except wheel/suspension alignment). Overhaul time should be used only if the time for individual parts (less overlap) is more than the overhaul time. Overhaul operations include component R&R procedure steps and inclusions unless otherwise noted.

## OVERLAP

When replacing two or more components the duplication of included labor procedures is known as overlap. Labor procedures (R&R/R&I/D&R) that create overlap include, but are not limited to, mechanical attachment, welding, bonding and/or technician preparation.

For example, when replacing a quarter panel and rear body panel on the same vehicle, the common required labor procedures necessary to remove and replace or reinstall these components is known as overlap.

When a labor overlap condition exists, less time is required to replace adjoining components collectively than is required when they are replaced individually.

Overlap labor information is generally included at the beginning of each group or subgroup within each chapter.





### R&I (Remove & Reinstall)

Item is removed, set aside and later reinstalled and aligned for proper fit (does not include Suspension/Wheel alignment). Generally used to gain access to another part.

If an R&I time is not available, published R&R times can be used when the steps required to R&R a component are the same procedure steps required to R&I a component. For example, bolt- or clip-on moldings, ornamentation, mirrors, trim, door handles, locks, cylinders, latches and many single-piece components. In addition, an equal sign (=) printed after an R&R time indicates MOTOR has evaluated an operation and determined that the R&R time may be used as the R&I time.

### R&R (Remove & Replace)

Remove old part, transfer necessary items to new part (unless otherwise noted in Labor Procedure pages), replace and align. Does not include Suspension/Wheel alignment.

### STRUCTURAL COMPONENT IDENTIFICATION

Structural component identification information as presented in I-CAR Enhanced Delivery programs.

Welded structural parts can be made from different types of metal. Identification is not based on metal type. Replacement requires specific measuring equipment and vehicle dimensions must be correct. If improperly repaired, road performance and/or crashworthiness of the vehicle may be affected. Airbag deployment may also be affected.

Welded structural parts on a unibody vehicle typically include:

- APRONS/STRUT TOWER
- CENTER PILLAR
- CORNER PILLAR
- FRONT RAIL
- HINGE PILLAR
- LOCK PILLAR
- RADIATOR CORE SUPPORT
- REAR RAIL
- REAR STRUT TOWER
- ROCKER PANEL
- SUSPENSION CROSSMEMBER
- UPPER RAIL

### STRUCTURAL COMPONENT IDENTIFICATION - Continued

Welded structural parts of the body on a body-over-frame vehicle typically include:

- APRON ASSEMBLY
- CAB CORNER (PICK-UP)
- CAB BACK PANEL (PICK-UP)
- CENTER PILLARS
- CORNER PILLARS
- FRONT RAIL
- HINGE PILLARS
- LOCK PILLARS
- RADIATOR CORE SUPPORT
- REAR RAIL
- ROCKER PANELS
- UPPER RAIL

Some parts that are bolted, bonded or welded may add structural integrity to a vehicle's body. These parts may be made from different types of materials and vehicle dimensions must be correct before replacement. If improperly repaired, road performance and/or crashworthiness of the vehicle may be affected. Air bag deployment may also be affected.

Parts that may add structural integrity to a vehicle's body may include:

- COWL ASSEMBLIES
- DASH PANEL
- ENGINE CRADLE (bolt-on)
- FLOOR PANEL
- IMPACT BAR (bolt-on)
- PERIMETER FRAME
- QUARTER PANEL
- RADIATOR CORE SUPPORT (bolt-on)
- REAR BODY PANEL
- ROOF PANEL
- STATIONARY GLASS (urethane bonded)

## ACOUSTICAL AND STRUCTURAL FOAM FILLERS

This type of product is used by some OEMs to control NVH (noise, vibration and harshness) or add structural integrity to the vehicle body. Acoustical foam is a soft to firm, pliable product while structural foam is a hard, dense, rigid product. Acoustical and/or structural fillers may be found internally on vehicle panels; therefore, identification of foam type and location may require an inspection after vehicle disassembly. Foam products must be removed if within six inches of an open flame, excessive heat (600 degrees) or welding operation. Any foam damaged or removed during the repair process must be replaced.

### SPECIAL NOTATION:

**Not all vehicles contain foam fillers; others may contain foam fillers in one or more locations. Refer to OEM for specific repair recommendations/procedures and replacement product(s).**

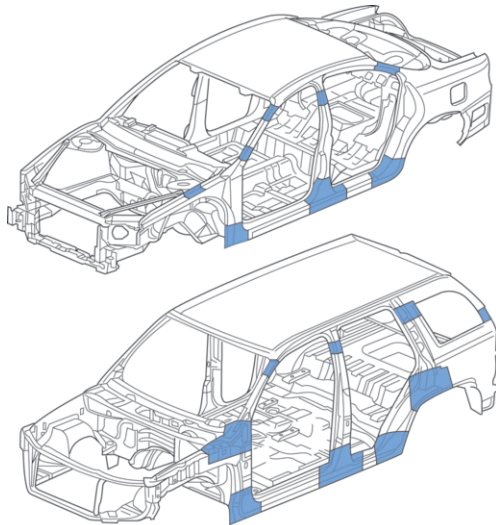

## AIR CONDITIONER REFRIGERANT

Reported refrigerant capacities are FOR ESTIMATING PURPOSES ONLY. ALWAYS refer to the vehicle A/C label or manufacturer's service manual for recommended repair procedures and system capacity.

## DAMAGED OR NON-REUSABLE MOLDINGS AND FASTENERS

Some moldings may be damaged or broken during normal R&I procedures. Additionally, some plastic or metal fasteners may be damaged and their ability to be reused jeopardized because of single-use design, age or exposure to the elements. Moldings, emblems and trim attached using a heat stake method are considered to be non-reusable. Caution should be taken while removing all fasteners, both metal and plastic. MOTOR recommends these factors be considered and mutually agreed upon before finalizing any repair cost estimate.

## ELECTRONIC SYSTEMS & ON-BOARD COMPUTERS

Special caution should be taken when servicing vehicles due to the wide use of computer modules, electronic sensors and printed circuit boards. This type of equipment is very sensitive to high temperatures and voltage fluctuations, including electrostatic discharge. A few safety tips you should consider are:

## ELECTRONIC SYSTEMS & ON-BOARD COMPUTERS - Continued

- Disconnect battery cable
- Computer modules should not be exposed to temperatures exceeding OEM recommendations
- Remove component if necessary
- Discharge static electricity before handling component(s)
- Avoid touching electrical terminals of component

I-CAR's Uniform Procedures for Collision Repair states that electronic components should be removed from the vehicle if welding is to take place within 12 inches of the component. Refer to manufacturer's specific recommendations for each vehicle.

## HAZARDOUS MATERIALS

Regulations and safety considerations may require protective clothing, respirator, protective eyeglasses, and/or ear plugs be worn in certain areas of collision repair facilities. Caution must be exercised when dealing with isocyanates, flammables, fumes, liquids and airborne particles.

## HYBRID/ELECTRIC VEHICLES

### Warning: High Voltage Electrical System!

These vehicles are equipped with high voltage batteries and are capable of causing electrical shock. Failure to use caution in the proper disconnection of this electrical system may result in serious injury or death. For safety and ease of identification, electrical cables carrying the high voltage are colored orange. Any orange-colored cable should be avoided until the high voltage electrical system has been disabled. Follow OEM safety precautions including wearing personal protective equipment rated for working on Hybrid/Electric Vehicles. Follow OEM service repair information for disabling the high voltage electrical system before beginning any repairs.

## OEM COLLISION REPAIR NETWORK

Some OEM(s) manufacture aluminum vehicles that have an established repair network for these vehicles and require collision repairs to be performed at an OEM authorized aluminum repair center. Manufacturers with collision repair networks covered in MOTOR's guide are Audi, BMW, Jaguar and Mercedes Benz. Refer to the OEM for complete information on collision repair network program.

## OEM COMPONENT REPLACEMENT - GENERAL

The collision repair facility must have the equipment, training, and experience using the latest factory/industry information and procedures. Ultimately, the safety and quality of any repair will depend not only on the equipment that is used and the procedure that is followed, but also on the skill and knowledge of the repair technicians, the steps they take to control repair quality and how well they check the details of the repair.

Some repair operations reported in this guide may be beyond the capability of the repair shop in terms of equipment, skill and knowledge, etc. In this case the repair shop should not attempt the repair.

MOTOR Information Systems expressly disclaims all warranties, obligations and liabilities, either expressed or implied, in the use of this guide. MOTOR Information Systems neither assumes, nor authorizes any party to assume for it, any liability in connection with the use of this guide.

Extreme care and caution should always be used when performing collision repairs on any vehicle. All repairs must be of the highest quality using the latest factory recommended repair procedures with the following concerns kept in mind:



**SPECIAL PRECAUTIONS**

### OEM COMPONENT REPLACEMENT - GENERAL - Continued

- **Passenger Protection:** Replacing damaged parts of a car designed to crush in a collision may reduce occupant protection in a future collision if the structural integrity is not restored.
- **Safety & Handling:** An improper repair can create braking, handling, vibration and noise problems. This may lead to possible safety problems.
- **Corrosion Protection:** A vehicle's ability to resist corrosion may be reduced if improper repairs are made and the manufacturer's corrosion protection is not restored. This may lead to future safety and/or resale value problems.
- **Resale Value:** The resale value of a vehicle can be reduced dramatically by improper repairs which may lead to a financial loss to the vehicle owner.

### PANEL BONDING (Metal Adhesives)

OEM labor procedures for "panel bonding" requires different procedural steps versus welding, such as panel/vehicle preparation, sectioning insert/sleeve, additional panel fit and adhesive application unless otherwise specified in a footnote attached to the sectioning operation. MOTOR published welded panel replacement labor times may be applied for "panel bonding" and would include all the necessary procedure steps as outlined by the OEM. Refer to the Guide to Estimating pages for specific INCLUDED/NOT INCLUDED operations. An adjustment in time may or may not apply after an on-the-spot evaluation of required procedures. Refer to OEM for specific repair recommendations/procedures and replacement product(s).

### PARTS SUPPLIED IN COLOR

Some replacement components such as instrument panels, trim panels and moldings can be ordered in various colors and therefore may not require painting. In some instances specific colors may no longer be available from the manufacturer and therefore would require painting. MOTOR recommends the availability of appropriate replacement colors be confirmed before finalizing any estimate of repairs. Refinishing time should be added if needed color is not available.

**NOTE:** Air bag components should never be refinished. Refinishing these components will alter the original design and change deployment characteristics.

### REFINISH CLEAR COAT APPLICATION

Most major paint manufacturers recommend that when performing refinish repairs on an OEM base coat/clear coat or multi-stage finishes, the application of clear coat must be extended to the nearest panel edge or breakpoint to qualify for their lifetime refinish warranties.

### RESTRAINT SYSTEM (Air Bag)

**NOTE:** RESTRAINT SYSTEMS, REPLACEMENT COMPONENTS and INSPECTION COMPONENTS are FOR ESTIMATING PURPOSES ONLY. Wiring repairs should only be performed in accordance with vehicle manufacturer specifications. Air bag components should never be refinished. Refinishing these components will alter the original design and change deployment characteristics. **Always refer to the vehicle manufacturer's recommended repair procedures when servicing any air bag system.**

Before repairing any air bag system, disconnect and isolate the battery cable so that any back-up power supply is discharged for the time period stipulated by the manufacturer to prevent accidental deployment when working on the vehicle. All system components and mounting areas must be inspected before energizing the system.

### RESTRAINT SYSTEM (Air Bag) - Continued

On some vehicles the windshield is considered an integral component of the overall system and has specific requirements regarding materials and procedures used when replacing a windshield. Factory recommended procedures must be followed when servicing this type of system. Some vehicles are equipped with dual stage air bags. The air bags are deployed at different rates depending on the severity of the crash, seat belt usage and driver position. If a dual stage air bag has deployed, it is possible that only one stage has deployed. If both stages have not deployed, there is a danger of the second stage deploying if the air bag is not properly handled. On vehicles that are equipped with dual stage air bags, ensure the air bag system is disabled before performing any repair procedures. The air bag should then be properly disposed of. Refer to the vehicle manufacturer's recommended procedures for air bag disposal.

Estimated Work Times for disabling vehicle safety restraint systems have been developed for instances where the OEM-recommended procedure steps required to disable the system are in addition to steps required to de-energize the vehicle by disconnecting the battery and/or removing a readily accessible fuse.

### RESTRAINT SYSTEM (Seat Belt)

Many automobile manufacturers recommend seat belt components be replaced when subjected to stress by occupants in a collision. Check with the manufacturer for specific repair recommendations and procedures.

### SECTIONING

Sectioning is an industry accepted procedure which involves replacing a vehicle's welded body panel (quarter, rocker, rail, etc.) onto the undamaged portion of a vehicle body at a location other than at a factory seam. This may or may not be a factory recommended procedure. Special care and training is required when sectioning any part due to the wide use of special steels and vehicle design. Repairs of this type should only be performed in accordance with the OEM service repair information, if available. When sectioning procedures are not available from the vehicle maker, it may be possible to section a part using vehicle-specific procedures developed by research organizations such as Tech-Cor and/or general sectioning guidelines taught by I-CAR. Please visit <http://www.i-car.com/partialreplacement> for more information.

The sectioning location may be affected after an on-the-spot evaluation of the vehicle's inner structure design.

The labor time premise (included/not included operations) for a sectioned panel is considered to be the same as for the full panel replacement, unless otherwise specified in a footnote attached to the sectioning operation. The on-the-spot evaluation will define inclusions/non-inclusions unique to the collision scenario and/or the sectioning approach chosen.

### SPECIAL SUBSTRATES

Some vehicle manufacturers use special or alternative materials in the construction of their vehicles. When possible, parts made from one of the eight listed materials will be identified using the abbreviations shown below.

It is not always possible or practical to identify where special or alternative materials are used on a vehicle. Do not assume that a part not identified as special material isn't actually made of a special material. When in doubt, it is recommended that you contact the vehicle manufacturer for further information. When performing repairs to special substrates, refer to OEM recommendations for specific information. Improper repairs may adversely affect the structural integrity and safety of the vehicle.



## SPECIAL SUBSTRATE METALS - Continued

**ALUMINUM (ALU):** Aluminum is lighter than steel and is non-magnetic. Aluminum is sensitive to galvanic corrosion. Only use fasteners, tools and materials that are designated for use on aluminum. Heat limitations MUST be observed when working with this type of metal. *Variances can be found in alloy, strength, temper, and gauge properties. Such variations need to be considered prior to attempting a repair, and an on-the-spot evaluation is required. Aluminum component repair and/or replacement often requires specific equipment and tools. Always consult OEM repair procedures for vehicle-specific information.*

**BORON STEEL (BOR):** Boron steel has extremely high strength; do not use heat on this type of metal. It cannot be straightened because of the extremely high heat used in the forming process. The only solution for damage is replacement. Boron steel can be cut with a cutoff wheel. Drilling boron steel is very difficult and may be accomplished using a titanium drill bit combined with slow speed (490 rpm).

**CARBON FIBER COMPOSITE (CFC):** Visible weave carbon fiber (non-painted) and non-visible weave carbon fiber (painted) parts are extremely lightweight and strong. Structural carbon fiber parts will require replacement if damaged. Manufacturers may have repair options for non-structural parts such as exterior panels, provided that the damage does not extend to an edge. Repairability options depend on the manufacturer's recommendations and procedures. Only use fasteners, tools and materials that are designated for use on carbon fiber.

**HIGH STRENGTH STEEL (HSS):** Generally frame rails, inner rocker panels, suspension crossmembers and upper apron rails are made of this material (this varies by manufacturer). Heat limitations MUST be observed when working with this type of steel. When in doubt, most manufacturers recommend all steel be treated as HSS steel.

**HYDROFORMED STEEL (HYD):** Hydroformed parts may be sectioned depending on the vehicle manufacturer's recommendation. Heat limitations MUST be observed when working with this type of steel.

**MAGNESIUM (MAG):** Magnesium is much lighter, stronger and more resistant to corrosion than steel. Magnesium has the tendency to crack or break either from collision damage or during straightening due to its quick work-hardening characteristics. Magnesium is also not weldable with common collision repair facility GMA (MIG) welding capabilities. Do not use oxyacetylene equipment or plasma arc cutting equipment around this or any other magnesium part. If magnesium catches on fire, it requires a class D fire extinguisher.

**SANDWICHED STEEL (SAS):** This type of steel (OEMs may have other names) is being used on the dash panels, floor panels and oil pans, etc. This product has an engineered non-steel layer sandwiched between two cold rolled layers of steel; do not use heat on this type of metal unless recommended by OEM. It is used to help lower sound levels and vibration. This product may or may not be weldable with common collision repair facility GMA (MIG) welding.

**SHEET MOLDING COMPOUND (SMC):** A high strength glass-reinforced thermoset molding material which is normally compression-molded and is used on some vehicle body outer panels and radiator supports. Manufacturers may have repair options for these types of non-structural parts. Repairability options depend on the manufacturer's recommendations and procedures. Only use materials that are designated for use on sheet molded compounds.

**ULTRA HIGH STRENGTH STEEL (UHS):** Generally door guard beams, bumper reinforcements and other special purpose areas contain this type of steel. These parts must not be repaired. They are to be replaced only. Contact the vehicle manufacturer for applicable locations. This information supersedes information published in previous Guide to Estimating pages.

## SPECIAL SUBSTRATE METALS - Continued

### Note:

Due to space limitations, special substrate information is not available in MOTOR CEG Online or DVD products.

## STEERING COLUMN

Many vehicle manufacturers use collapsible steering columns to absorb energy sustained from a collision impact. These columns should be inspected for proper length, binding and deformation among other specific considerations. Failure to do so may prevent proper operation of steering column and/or air bag deployment. MOTOR recommends following vehicle manufacturer's guidelines for inspection and replacement of these components.

## STONE CHIP GUARD (Protective Material)

Vehicle manufacturers may apply a spray-on, chip-resistant coating to protect the vehicle's finish from chipping. This type of coating may be named differently depending on manufacturer ex.: Stone Guard, Soft-chip Primer, PVC Chipping Primer, Chip Guard, Gravel Guard, etc. This type of coating is designed to reduce paint chipping; appearance varies from textured surface to a smooth surface. Chip-resistant coatings may be applied to the vehicle's lower body and/or leading edges of the body. Refer to OEM service repair information for specific location, repair recommendations and/or replacement product(s). MOTOR recommends following OEM service repair information for replacement of these materials following a thorough on-the-spot evaluation of vehicle and damage in question.

## STRUCTURAL GLASS

Urethane bonded stationary glass such as windshields, side/quarter glass and back glass adds structural integrity to a vehicle's body and may be considered a structural component on some vehicles. Therefore, it is important to use proper materials and procedures when installing this type of glass. I-CAR and some vehicle manufacturers recommend the use of epoxy primer on glass pinchweld where coating has been removed. Utilization of incorrect methods or materials could result in a failure to restore the vehicle's original structural integrity. Removal of some undamaged urethane bonded glass for reuse may not be possible due to damaging plastic locating studs and/or attached moldings. Some vehicle manufacturers recommend replacing glass that has been removed with new OEM glass. It is MOTOR's position that removal of the glass from the damaged part/panel for reuse is a process best reserved for the judgment of an estimator/appraiser following a thorough review of vehicle manufacturer guidelines.

## WELDER SET-UP AND WELDING PREPARATION

Due to the different types of welding equipment used in the collision repair industry, labor times for welded replaced parts do not include equipment manufacturer procedural steps for welder setup and/or welding tests and preparation. Each welding machine manufacturer may have its own unique configurations and setup processes. Additionally, there may be vehicle-specific variables that may increase or decrease the amount of welding machine set-up time and pre-weld preparation. MOTOR suggests using an on-the-spot evaluation to determine an appropriate set-up and preparation time.



SPECIAL PRECAUTIONS



### LABOR TIME LISTINGS

All operation times are listed in hours and tenths of an hour. A time listed as 3.5 indicates three and one half hours.

### LABOR TIME PREMISE

The times reported in this publication are to be used as a GUIDE ONLY. Reported times include normal align procedure to insure proper fit of the individual new part being replaced. Reported times include tube/paddled OEM caulking and seam sealer removal/application on welded replacement panels. Sprayable seam sealer equipment requires preparation and adjustment before application and is NOT INCLUDED IN LABOR TIME.

Times do not apply to vehicles with equipment other than that supplied by the vehicle manufacturer as standard or regular production options. If other equipment is used, the time may be adjusted to compensate for the variables. Removal and replacement of exchanged or used parts is not considered. If additional aligning or repair must be made, such factors should be considered when developing the estimate. Items not listed under the INCLUDED/DOES NOT INCLUDE heading for any given procedure have not been considered in the estimated work time development for that procedure, unless specified by a footnote. All included/not included items for labor procedures listed between pages G10 and G33 are for component R&R and R&I procedures unless otherwise indicated in operation heading.

Many OEMs recommend a pre- and post-repair diagnostic scan on all vehicles involved in a collision that could reveal pre-accident or accident-related damage. Please refer to OEM position statement and repair procedures for more information.

OPERATION TIMES LISTED ARE BASED ON NEW UNDAMAGED PARTS INSTALLED ON NEW UNDAMAGED VEHICLES AS INDIVIDUAL OPERATIONS. TIME HAS NOT BEEN CONSIDERED FOR ALIGNMENT PULLS, DAMAGE-RELATED ACCESS TIME, DAMAGED, USED, REMANUFACTURED OR AFTERMARKET PARTS. SOME OPERATION TIMES ARE APPLICABLE AFTER BOLTED, ATTACHED OR RELATED PARTS HAVE BEEN REMOVED. REFER TO SPECIFIC FOOTNOTES ATTACHED TO OPERATION TIME LISTING.

#### LABOR TIME DOES NOT INCLUDE:

#### SPECIAL NOTATION:

The items listed below apply to all labor procedures.

- A/C System, Evacuate and Recharge
- Aftermarket & OEM accessories
- Alignment, check or straightening related parts
- Alignment check of front or rear suspension/steering
- Anticorrosion material restoration/application
- Battery D&R/recharge
- Brackets & braces transfer
- Broken glass removal or clean up
- Brakes, bleed and adjust
- Caulk (non-OEM), sound insulate or paint inner areas
- Clean up or detailing of vehicle prior to delivery
- Computer control module D&R/relearn
- Conversion Vans (special components, equipment and trim)
- Cutting, pulling or pushing collision damaged parts for access
- Damaged or defective replacement parts
- Drain & refill fuel tank
- Drilling, modification or fabrication of mounting holes
- Fabricate templates, reinforcing inserts, sleeves or flanges
- Filling, plugging and finishing of unneeded holes in new parts
- Information label installation

### LABOR TIME PREMISE - Continued

- Material costs
- Pinch weld clamp damage repair
- Refinishing
- Reset electronic memory functions after battery disconnect
- Road test vehicle
- Rusted, frozen, broken or corrosion damaged components or fasteners
- Scan tool clear/reset electronic module
- Scan tool diagnostics
- Steering Angle Sensor recalibration
- Straighten or align used, reconditioned or non-OEM parts
- Structural damage diagnosis and vehicle set up time
- Structural foam removal or application
- Test for water leaks (except Windshield, Back Glass, and Stationary Glass)
- Test panel/spray caulk
- Undercoating, tar or grease removal
- Unprimed bumpers, removal of mold-release agents
- Waste disposal fees (all types)
- Weld through primer
- Welded seam surface finishing finer than 150 grit sandpaper
- Welder set-up or preparation
- Wheel or hub cap locks R&I

### FRONT BUMPER ASSEMBLY - R&I ALL TYPES

#### INCLUDED:

- Align to vehicle
- Face bar/bumper cover assembly R&I

#### DOES NOT INCLUDE:

- Air bag sensor
- Battery
- Emblems & nameplates
- Energy absorber, all types
- Lamp aiming
- Lamps (when not mounted in bumper)
- Moldings & impact strip
- Stripe tape, decals or overlays
- Valance panel/spoiler (when not mounted to bumper)

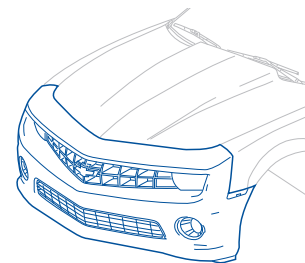

### FRONT BUMPER - R&R FACE BAR TYPE

#### INCLUDED:

- Align to vehicle
- Emblem & nameplate
- Face bar R&I
- Guard
- Guard cushions
- Lamps (when mounted to bumper)
- Molding & impact strip

#### DOES NOT INCLUDE:

- Air bag sensor
- Battery
- Distance sensor
- Energy absorber, if mounted to frame rail (all types)
- Lamp aiming
- Lamps (optional equipment, or not mounted to bumper)
- License plate/bracket
- Stripe tape, decals or overlays
- Valance panel/spoiler (when not mounted to bumper)

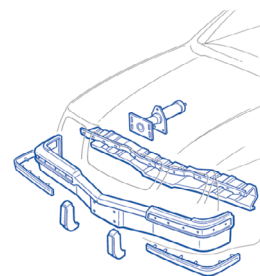

# GUIDE TO ESTIMATING

## FRONT BUMPER ASSEMBLY – OVERHAUL FACE BAR TYPE

### INCLUDED:

- Align to vehicle
- Disassemble complete assembly
- Emblem & nameplate
- Guards
- Guard cushions
- Lamps (when mounted to bumper)
- Molding & impact strip
- Reassemble complete assembly
- Replace damaged parts

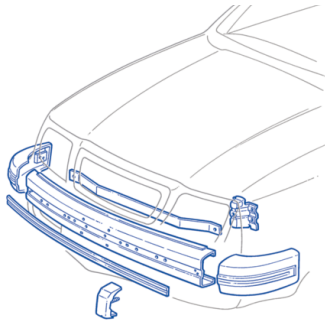

### DOES NOT INCLUDE:

- Air bag sensor
- Battery
- Distance sensor
- Energy absorber, if mounted to frame rail (all types)
- Lamp aiming
- Lamps (optional equipment, or not mounted to bumper)
- License plate/bracket
- Stripe tape, decals or overlays
- Valance panel/spoiler (when not mounted to bumper)

## FRONT BUMPER – R&R COVER TYPE

### SPECIAL NOTATION:

The removal of mold-release agents from and preparation/priming of unprimed bumpers is required and is NOT INCLUDED. Where the OEM has provided information regarding the availability of unprimed bumper covers, an "Add if Required" labor operation has been added to the bumper group.

### INCLUDED:

- Align to vehicle
- Emblem & nameplate
- Energy absorber (when mounted to cover)
- Front bumper cover R&R
- Grille (when mounted to bumper)
- Lamps (when mounted to bumper)
- Molding & impact strip

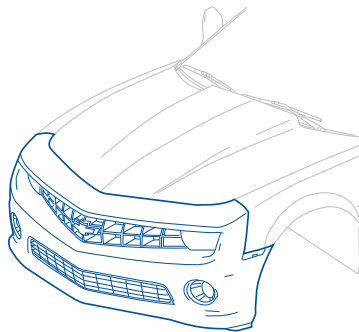

### DOES NOT INCLUDE:

- Aim lamps
- Air bag sensor
- Battery
- Bumper brackets/frame rail extensions (if mounted to frame)
- Distance sensor
- Lamps (optional equipment, or not mounted to bumper)
- License plate/bracket
- Reinforcement/impact bar
- Stripe tape, decals or overlays
- Valance Panel/spoiler (when not mounted to bumper)

## FRONT BUMPER COVER – OVERHAUL COVER TYPE

### SPECIAL NOTATION:

The removal of mold-release agents from and preparation/priming of unprimed bumpers is required and is NOT INCLUDED. Where the OEM has provided information regarding the availability of unprimed bumper covers, an "Add if Required" labor operation has been added to the bumper group.

### INCLUDED:

- Align to vehicle
- Disassemble cover assembly
- Emblem & nameplate
- Energy absorber (when mounted to cover)
- Grille (when mounted to bumper)
- Lamps (when mounted to bumper)
- Molding & impact strip
- Reassemble unit
- Replace damaged parts

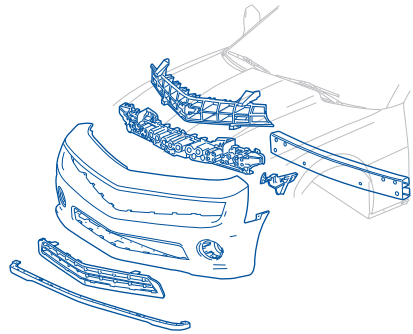

### DOES NOT INCLUDE:

- Aim lamps
- Air bag sensor
- Battery
- Bumper brackets/frame rail extensions (if mounted to frame rail)
- Drill time
- Distance sensor
- Lamp aiming
- Lamps (optional equipment, or not mounted to bumper)
- License plate/bracket
- Reinforcement/impact bar
- Stripe tape, decals or overlays
- Valance panel/spoiler (when not mounted to bumper)

## VALANCE PANEL

### INCLUDED:

- Brackets/braces
- Lamps
- Grilles

### DOES NOT INCLUDE:

- Air dam
- Bumper assembly
- Emblems & nameplates
- Moldings
- Spoilers & flares

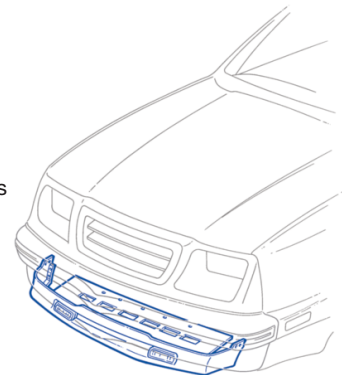

# GUIDE TO ESTIMATING



## FRAME - UNITIZED FRAME VEHICLES

### INCLUDED:

- Caulk/seam sealer
- Welding as necessary

### DOES NOT INCLUDE:

- Adjacent panels
- Body sheet metal
- Bolted-on parts (brackets & braces)
- Brakes adjust & bleed
- Drive train assembly
- Electrical wiring
- Floor mats, insulation & trim
- Pulling or straightening time
- Set up on frame machine & diagnosis
- Suspension/wheel alignment

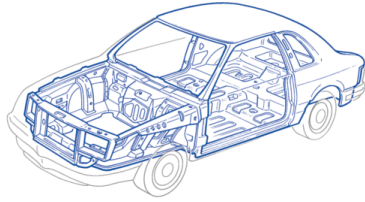

## FRAME - CONVENTIONAL FRAME VEHICLES

### INCLUDED:

- Bed assembly R&I (truck)
- Body assembly R&I
- Brackets (bolted-on)
- Bumper assemblies front/rear R&I
- Bushings
- Clips
- Drive shaft
- Drivetrain as assembly R&I
- Engine & transmission R&I
- Front sheet metal R&I (as an assembly when practical)
- Fuel tank (primary)
- R&I independent rear suspension (LT & RT side assemblies, axles and housing)
- Stabilizer bar
- Transfer steering gear and linkage as an assembly
- Steering gear/gear assembly R&R/R&I
- Suspension assemblies R&I
- Transfer lines to new assembly

### DOES NOT INCLUDE:

- Auxiliary fuel tank (second tank)
- Brackets (weld on)
- Brakes adjust & bleed
- Electrical wiring
- Exhaust systems
- Fluids (top off)
- Heat shields
- Interior trim/carpet
- Parking brake adjust
- Power steering cooler
- Pulling or straightening time
- Seats
- Shift & throttle linkage adjust
- Special equipment transfer

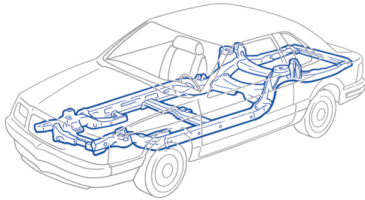

## FRAME - CONVENTIONAL FRAME VEHICLES - Continued

- Steering gear individual components R&R/R&I
- Suspension/wheel alignment
- Trailer hitch
- Transfer fuel (hold tank if necessary)
- Transmission cooler
- Wheels

## FRAME CROSSMEMBERS R&R - FRONT, REAR or SUSPENSION MOUNT, BOLTED TYPE

### INCLUDED:

- Attached parts R&I
- Crossmember R&R
- Support engine (if required)

### DOES NOT INCLUDE:

- Attached parts R&R
- Brakes bleed or adjust
- Suspension/wheel alignment
- Exhaust system components
- Fuel tank

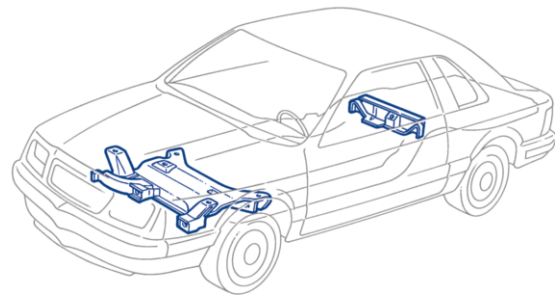

## FRAME CROSSMEMBERS R&R - FRONT, REAR or SUSPENSION MOUNT, WELDED TYPE

### INCLUDED:

- Attached parts R&I
- Support engine (if required)
- Welding as necessary

### DOES NOT INCLUDE:

- Attached parts R&R
- Brakes adjust & bleed
- Suspension/wheel alignment

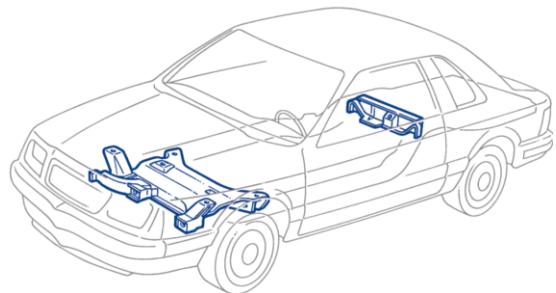

# GUIDE TO ESTIMATING

## GRILLE

### INCLUDED:

- Emblems & nameplates
- Grille
- Lamp (in grille)
- Moldings & ornamentation

### DOES NOT INCLUDE:

- Adjacent panels or components
- Lamp aiming
- Stripe tape/decals

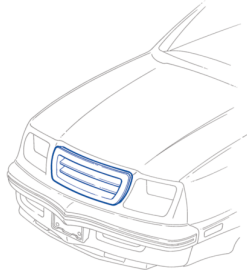

## HEADER PANEL OR HEADLAMP MOUNTING PANEL

### INCLUDED:

- Align to vehicle
- Bolt on extensions & fillers
- Emblems & nameplates
- Grille
- Lamp
- Moldings
- Ornamentation

### DOES NOT INCLUDE:

- Bumper assembly
- Lamp aiming
- Stripe tape, decals or overlays

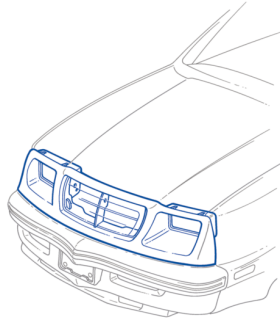

## RADIATOR

### SPECIAL NOTATION:

If R&R of a coolant hose, connected to both the radiator and water pump, is combined with removal of the radiator and water pump, then no additional time should be estimated for R&R or R&I of that coolant hose.

### INCLUDED:

- Drain, check and refill fluids
- Electric fan assembly R&I
- Purge air from system

### DOES NOT INCLUDE:

- Belts
- Cost of coolant
- Electric fan assembly O/H or R&R
- Mechanical fan
- Pulley

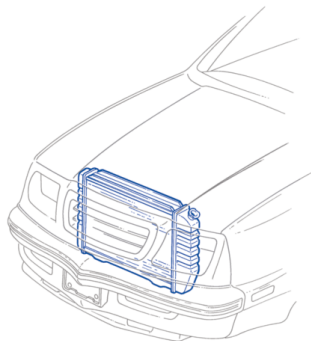

## RADIATOR SUPPORT

### SPECIAL NOTATION:

Operations/components included with R&R radiator support are listed in FOOTNOTES in each chapter and below as INCLUDED.

### INCLUDED:

- Caulk/seam sealer
- Included parts are listed in footnote in each chapter
- Welding as necessary

### DOES NOT INCLUDE:

- See "LABOR TIME PREMISE" DOES NOT INCLUDE

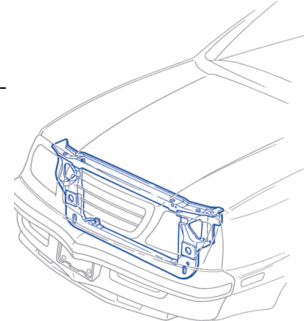

## HEATER

### INCLUDED:

- R&R time is listed with parts

### DOES NOT INCLUDE:

- Cost of coolant
- Drain and refill fluids

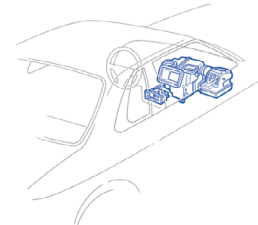

## AIR CONDITIONER

### SPECIAL NOTATION:

A "Refrigerant Recovery" procedure should be considered prior to any repair necessitating a refrigerant line disconnect from an A/C system containing refrigerant. Published recovery time is for a service technician to operate and periodically monitor typical refrigerant recovery & recycling equipment as the vehicle's existing refrigerant is transferred out of the vehicle and into the machine (0.3) and reprocessed by the machine (0.1).

Recovery time does not include overall recycling machine processing time, nor does it include "A/C Service" which is the evacuation, recharge and testing of an A/C system following repairs.

### INCLUDED:

- R&R time is listed with parts

### DOES NOT INCLUDE:

- Cost of refrigerant & oil
- Cost of seals or O-rings
- Refrigerant recovery
- Test for leaks
- Retrofit for 134a

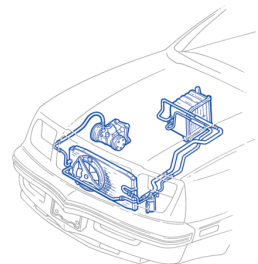

# GUIDE TO ESTIMATING



## HOOD

### SPECIAL NOTATION:

Some replacement components may or may not be supplied with duplicated OEM caulk/seam sealer, This is not included in R&R time and requires an on-the-spot evaluation.

Disconnect hood at hinges.

### INCLUDED:

- Air inlet system (if necessary)
- Align to vehicle
- Grille (if attached)
- Hood lamp
- Hood panel R&R
- Insulation
- Scoop
- Safety catch
- Striker
- Washer hoses & nozzle (mounted to hood)
- Weatherstrips & seals (mounted to hood)

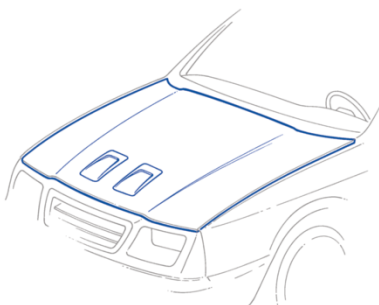

### DOES NOT INCLUDE:

- Emblems & nameplates
- Hinge
- Hood lock
- Moldings & ornamentation
- Stripe tape, decals or labels

## FRONT LAMPS (Composite Type)

### INCLUDED:

- Bulb(s)

### DOES NOT INCLUDE:

- Lamp aiming
- Headlamp door/bezel

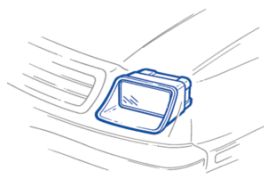

## FRONT LAMPS (Sealed Beam Type)

### INCLUDED:

- Mount ring
- Retainer ring
- Sealed beam

### DOES NOT INCLUDE:

- Lamp aiming
- Headlamp door/bezel



## FENDER - OUTER PANEL

### INCLUDED:

- Align to vehicle
- Fillers (if mounted to fender)
- Cornering lamps (if mounted to fender)
- Fender liner
- Scoop
- Side marker
- Side repeater lamp (if mounted to fender)

### DOES NOT INCLUDE:

- Antenna
- Bumper R&I
- Battery
- Emblems & nameplates
- Grille
- Header panel
- Hood
- Inner panels
- Lamp aiming
- Mirror
- Moldings
- Mud guard
- Road wheel
- Spoilers & flares
- Stripe tape, decals or overlays

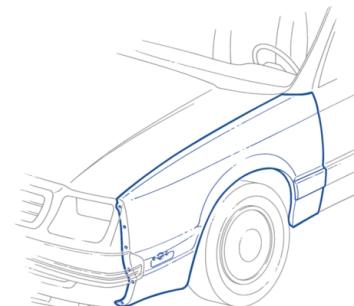

## FENDER - INNER PANEL (Welded Apron & Rails)

### SPECIAL NOTATION:

Detach and weld at floor pan, radiator support, hinge pillar and cowl panel.

### INCLUDED:

- Adhesive application if required (all types)
- Battery tray
- Carpet & insulation turn back
- Caulk/seam sealer
- Cowl trim
- Cutting & welding as necessary
- Grind, fill and smooth welded seams (up to 150 grit sandpaper)

### DOES NOT INCLUDE:

- Adjacent panels
- Air inlet system (if necessary)
- Attached standard items
- Battery
- Bolted-on parts
- Bumper assembly
- Carpet, insulation or seat R&I
- Cruise control
- Dash panel
- Decals/labels

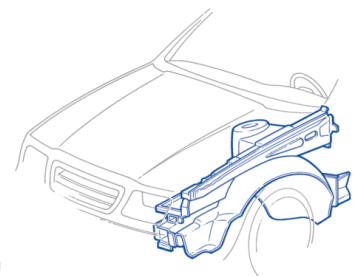

# GUIDE TO ESTIMATING

## FENDER – INNER PANEL (Welded Apron & Rails) - Continued

- Electrical wiring
- Energy absorber
- Engine
- Front suspension assembly
- Hood hinges & support cylinder
- Horns
- Outer sheet metal
- Pulling or straightening time
- Reservoir
- Set up on frame machine & diagnosis
- Steering components
- Suspension/wheel alignment
- Washer/Coolant reservoir
- Welded brackets & braces transfer

## FENDER – FRONT RAILS

### INCLUDED:

- Adhesive application if required (all types)
- Carpet & insulation turn back
- Caulk/seam sealer
- Cowl trim
- Cutting & welding as necessary

### DOES NOT INCLUDE:

- Adjacent panels
- Battery
- Bolted-on parts
- Bumper assembly
- Carpet, insulation or seat R&I
- Decals/labels
- Electrical wiring
- Energy absorber
- Engine
- Exhaust system
- Front suspension
- Outer sheet metal
- Pulling or straightening time
- Set up on frame machine & diagnosis
- Steering components
- Suspension/wheel alignment
- Welded bracket & braces transfer

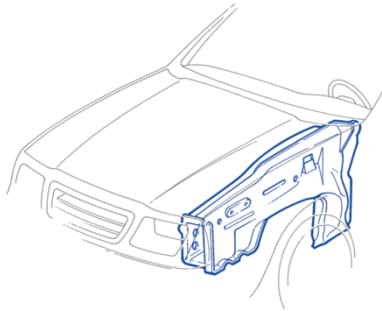

## ENGINE/TRANSAXLE ASSEMBLY R&I

### CONVENTIONAL FRAME VEHICLES

#### INCLUDED:

- Air cleaner
- Hoist or lift attach
- Splash shields (if necessary)

#### DOES NOT INCLUDE:

- A/C condenser
- Drain & replace oil and fluids
- Evacuate & recharge A/C system
- Linkage adjustments
- Radiator
- Replacement of any parts
- Road test vehicle

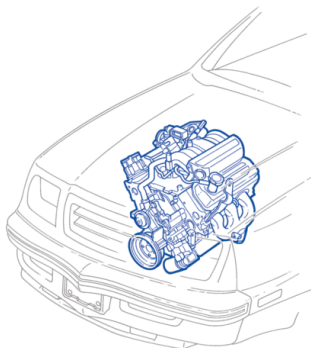

## ENGINE/TRANSAXLE ASSEMBLY R&I - Continued

### UNITIZED FRAME VEHICLES

#### INCLUDED:

- Air cleaner
- R&I Engine/Transaxle with R&I engine cradle and suspension (both sides) as one unit
- Hoist or lift table attach
- Splash shields (if necessary)

#### DOES NOT INCLUDE:

- A/C condenser
- Drain & replace oil and fluids
- Evacuate & recharge A/C system
- Linkage adjustments
- Radiator
- Replacement of any parts
- Road test vehicle
- Road wheel
- Suspension/wheel alignment

## ROAD WHEEL – R&R

### SPECIAL NOTATION:

When required, an additional 0.3 hrs. may be necessary to remove a spare tire from its storage location and install it on the hub and to later remove the spare tire from hub and return it to the original storage location.

#### INCLUDED:

- Raise & support vehicle
- Remove & reinstall wheel/tire assembly
- Transfer tire
- Lower vehicle
- TPMS sensor, if attached to valve stem
- Valve stem

#### DOES NOT INCLUDE:

- Balancing
- Cost of valve stems or weights
- Lock type lug nuts
- Lock type wheel covers
- Scan tool clear/reset
- Tire disposal fee

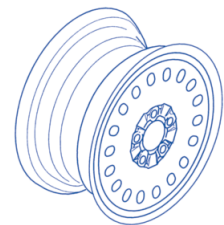

## BLEED BRAKE HYDRAULIC SYSTEM

### SPECIAL NOTATION:

Bleed Brake System operation times are based upon other suspension and/or brake work already being performed and the Bleed Brake System Operation performed in conjunction with those other operations.

#### INCLUDED:

- Bleed brake system
- Add fluid to master cylinder reservoir

#### DOES NOT INCLUDE:

- Brakes adjust
- Cost of brake fluid



# GUIDE TO ESTIMATING



## FRONT SUSPENSION - INDIVIDUAL OPERATIONS

### INCLUDED:

- Raise & support vehicle (one time)

### DOES NOT INCLUDE:

- Brake calipers R&I
- Brake pads or shoes
- Brakes adjust & bleed
- Road wheel
- Suspension/wheel alignment

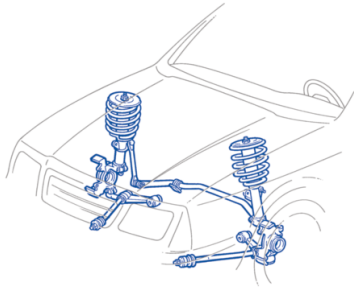

## FRONT SUSPENSION - OVERHAUL STRUT TYPE

### INCLUDED:

- ABS sensor
- Air suspension components
- Ball joint
- Bearing
- Bearing seal
- Brake rotor
- Coil spring & components
- Coil spring cap
- Hub
- Knuckle
- Lower control arm
- Lower control arm bushing
- Overhaul procedure as defined
- Raise & support vehicle (one time)
- Splash shield
- Stabilizer bar end/link
- Steering arm
- Strut radius rod & bushing
- Strut cartridge/assembly
- Strut seat

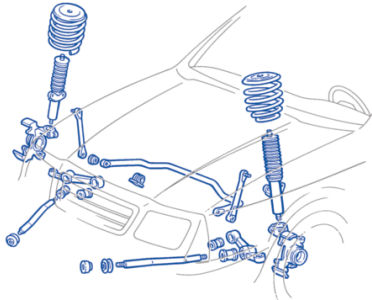

### DOES NOT INCLUDE:

- Brake calipers R&I
- Brake pad or shoes
- Brakes adjust & bleed
- Crossmember
- Drivetrain components
- Road wheel
- Stabilizer bar
- Steering linkage
- Steering gear
- Suspension/wheel alignment
- Wheel cylinders

## FRONT SUSPENSION - OVERHAUL S.L.A. TYPE

### SPECIAL NOTATION:

S.L.A. is defined as short upper control arm and long lower control arm. This includes Ball Joint and Torsion Bar Systems.

### INCLUDED:

- ABS sensor
- Ball joint
- Bearing seal R&R
- Bearing
- Brake rotor
- Coil spring components
- Hub
- Knuckle
- Lower control arm components
- Overhaul procedure as defined
- Radius rod & bushing
- Raise & support vehicle (one time)
- Shock absorber
- Splash shield
- Steering arm
- Torsion bar
- Upper control arm components

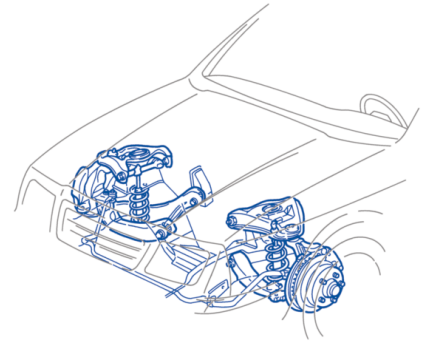

### DOES NOT INCLUDE:

- Axle or carrier assy (FWD or AWD)
- Brake calipers R&I
- Brake pad or shoes
- Brakes adjust & bleed
- Crossmember
- Road wheel
- Stabilizer bar
- Steering gear or linkage
- Suspension/wheel alignment



# GUIDE TO ESTIMATING

## FRONT SUSPENSION - OVERHAUL I-BEAM/TUBE TYPE

### INCLUDED:

- ABS sensor
- Axle beam/tube
- Ball joints
- Bearing seal R&R
- Bearing
- Brake rotor
- Coil spring seat
- Coil spring
- Coil spring insulator
- Control arms
- Hub
- Knuckle/spindle
- Overhaul procedure as defined
- Raise & support vehicle (one time)
- Radius rod & bushing
- Shock absorber
- Splash shield
- Steering arm

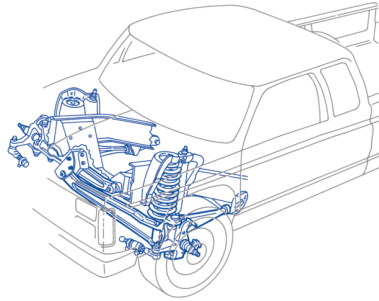

### DOES NOT INCLUDE:

- Axle or carrier assy (4WD) R&I
- Brake caliper R&I
- Brake pad or shoes
- Brakes adjust & bleed
- Drive train parts
- Road wheel
- Stabilizer bar
- Steering gear or linkage
- Suspension/wheel alignment

## STEERING LINKAGE - INDIVIDUAL OPERATIONS

### INCLUDED:

- Individual component R&R

### DOES NOT INCLUDE:

- Brakes adjust & bleed
- Road wheel
- Suspension/wheel alignment

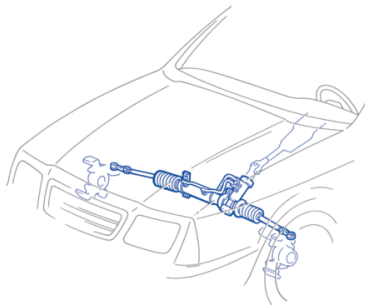

## STEERING COLUMN - OVERHAUL OPERATIONS

### SPECIAL NOTATION:

Air bag considerations are included in all steering column overhaul operations unless an "ADD IF REQUIRED" heading is listed in the text.

### INCLUDED:

- Column housing
- Column lower shroud
- Column internal parts
- Column upper shroud
- Cruise control parts attached to column
- Ignition lock cylinder
- Ignition switch
- Levers
- Lower coupling
- Shift lever
- Shift bowl
- Steering shafts
- Steering shaft bearings
- Steering wheel
- Tilt mechanism
- Turn signal switch/lever

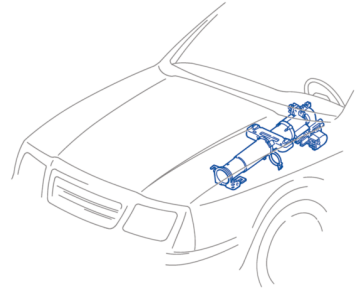

### DOES NOT INCLUDE:

- Electrical wiring
- Lock cylinder recoding
- Refinish column components

## SUSPENSION/WHEEL ALIGNMENT

### SPECIAL NOTATION:

Operations outlined in the following section are based on four wheel sensor alignment equipment. Alignment time includes normal wear diagnosis. Alignment time does not include collision related damage diagnosis.

### FRONT WHEEL ALIGNMENT

#### INCLUDED:

- Align front wheels
- Center steering wheel
- Check vehicle height & thrust angle
- Check and adjust tire pressure
- Check wheel size & run out
- Remove vehicle from alignment equipment
- Road test vehicle
- Set up on alignment equipment & normal wear diagnosis
- Shimming as required

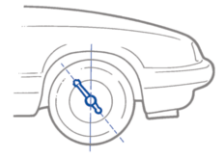

#### DOES NOT INCLUDE:

- Adjust brakes
- Adjust vehicle height
- Align rear wheels
- Alignment shim cost

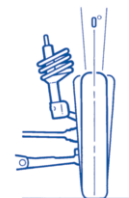



### SUSPENSION/WHEEL ALIGNMENT - Continued

#### REAR WHEEL ALIGNMENT

##### INCLUDED:

- Align rear wheels
- Check and adjust tire pressure
- Check vehicle height & thrust angle
- Check wheel size & run out
- Remove vehicle from alignment equipment
- Road test vehicle
- Set up on alignment equipment & normal wear diagnosis
- Shimming as required

##### DOES NOT INCLUDE:

- Adjust vehicle height
- Adjust brakes
- Align front wheels
- Alignment shim cost

#### 4 WHEEL ALIGNMENT

##### INCLUDED:

- Align front & rear wheels
- Center steering wheel
- Check vehicle height & thrust angle
- Check wheel size & run out
- Check and adjust tire pressure
- Remove vehicle from alignment equipment
- Road test vehicle
- Set up on alignment equipment & normal wear diagnosis
- Shimming as required

##### DOES NOT INCLUDE:

- Adjust brakes
- Adjust vehicle height
- Alignment shim cost

### COWL, HINGE PILLAR & DASH PANEL

##### INCLUDED:

- Adhesive application if required (all types)
- Carpet & mats turn back
- Caulk/seam sealer
- Cowl side trim
- Cutting & welding as necessary
- Grind, fill & smooth welded seams (up to 150 grit sandpaper)
- Hinge pillar glass and moldings
- Jamb switch
- Sill plates
- Weatherstrips

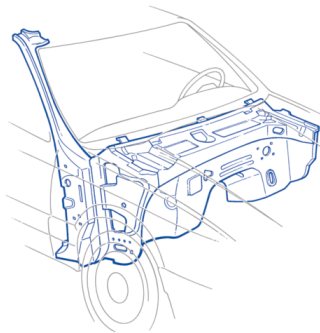

### COWL, HINGE PILLAR & DASH PANEL - Continued

##### DOES NOT INCLUDE:

- Air bags
- Air conditioning parts
- Bolted-on parts
- Carpet, insulation & seat R&I
- Door
- Door hinge
- Electrical wiring
- Engine
- Fender
- Foam
- Headliner
- Hinge plate transfer
- Instrument panel or crash pad
- Interior moldings
- Parking brake assembly
- Roof rail molding
- Windshield glass
- Windshield reveal moldings

### INSTRUMENT PANEL

##### SPECIAL NOTATION:

**Air bag considerations are included in all Instrument Panel operations unless an "Add If Required" heading is listed in text.**

##### INCLUDED:

- Crash pad R&I
- Emblems & nameplates
- Glove box R&I
- Heater & A/C controls
- Instrument cluster R&I
- Lamps & switches
- Metal reinforcement
- Moldings & ornamentation R&I
- Radio
- Speakers

##### DOES NOT INCLUDE:

- Console
- Inner cowl support braces & brackets
- Remote control mirrors
- Steering column

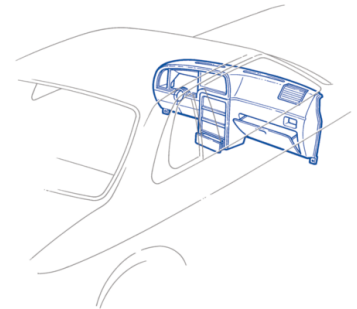

# GUIDE TO ESTIMATING

## CONSOLE - FLOOR OR OVERHEAD

### INCLUDED:

- Console
- Emblems & nameplates
- Gauges
- Moldings & ornamentation
- Shift lever (if necessary)

### DOES NOT INCLUDE:

- Front seat R&I (if necessary)
- Headliner R&I
- Instrument panel
- Straightening inner panels, brackets or braces
- Sunvisors

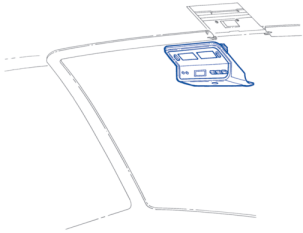
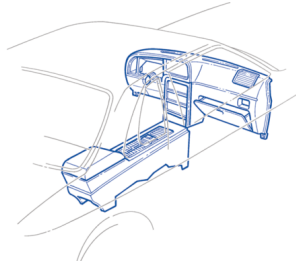

## ROOF - ROOF PANEL R&R

### SPECIAL NOTATION:

This section applies to passenger cars, trucks and vans.

### INCLUDED:

- Adhesive application if required (all types)
- Back glass & moldings
- Caulk/seam sealer
- Cutting & welding as necessary
- Flutter material
- Glass run channels
- Grind, fill & smooth welded seams (up to 150 grit sandpaper)
- Headliner, coat hooks & grab handles
- High-mounted stop lamp (if attached to roof)
- Lamp (dome, reading)
- Liftgate R&I
- Moldings
- OEM sunroof or "T" top R&I
- Quarter glass and reveal moldings (if overlapping roof)
- Rear view mirror/support R&I (attached to roof)
- Reveal & interior moldings/trim
- Sunvisor
- Upper quarter trim panels
- Weatherstrips & retainers
- Windshield glass

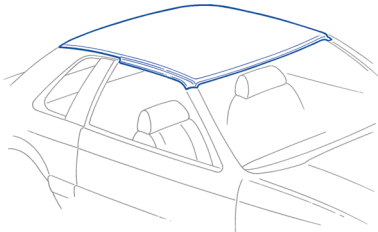

## ROOF - ROOF PANEL R&R - Continued

### DOES NOT INCLUDE:

- Electrical wiring
- Emblems & nameplates
- GPS Antenna
- Head air bags
- Header panels
- Lamp (exterior)
- Luggage racks
- Overhead console
- Rear package tray trim
- Roof covers
- Roof rails
- Stripe tape/decals

## ROOF - CONVERTIBLE TOP R&R

### INCLUDED:

- Boot well
- Fabric cover R&R
- Frame assembly R&R
- Quarter trim panels
- Weatherstrips & retainers

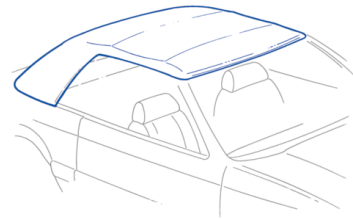

### DOES NOT INCLUDE:

- Deck lid
- Frame assembly alignment
- Ornamentation
- Power cylinder
- Roll bar
- Windshield frame

## ROOF - HEADLINER R&R

### INCLUDED:

- Coat hooks
- Grab handles
- High-mounted stop lamp (if attached to headliner)
- Lamp (dome, reading)
- Reveal & interior moldings/trim
- Sunvisor
- Sunvisor bracket

### DOES NOT INCLUDE:

- Head air bags
- Overhead console
- Seats

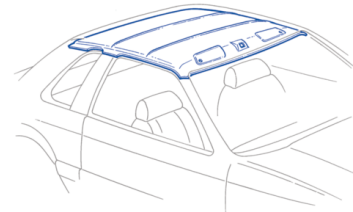

# GUIDE TO ESTIMATING



## WINDSHIELD GLASS

### SPECIAL NOTATION:

Glass, moldings, mounting studs or mounting flange may be damaged or broken during normal service procedures on some applications. MOTOR advises that these factors be considered before performing glass operations in the event unavoidable damage occurs. Time for the removal of old urethane, clean and preparation of sealing surfaces (vehicle and/or glass) should be estimated after an on-the-spot evaluation.

### INCLUDED:

- Cowl vent panel/screen (if overlapping glass)
- Rear view mirror/support (attached to glass)
- Reveal & interior moldings/trim
- Rubber channel R&I (if installed)
- Test for leaks
- Urethane adhesive application
- Wiper arms

### DOES NOT INCLUDE:

- Clean up of broken glass
- Cost of installation material or kit
- Refinish glass pinchweld (epoxy primer)

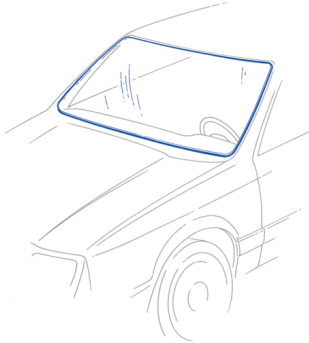

## BACK GLASS

### SPECIAL NOTATION:

Glass, moldings, mounting studs or mounting flange may be damaged or broken during normal service procedures on some applications. MOTOR advises that these factors be considered before performing glass operations in the event unavoidable damage occurs. Time for the removal of old urethane, clean and preparation of sealing surfaces (vehicle and/or glass) should be estimated after an on-the-spot evaluation.

### INCLUDED:

- Reveal & interior moldings/trim
- Rubber channel (if installed)
- Test for leaks
- Urethane adhesive application
- Wiper arm

### DOES NOT INCLUDE:

- Clean up of broken glass
- Cost of installation material or kit
- High-mounted stop lamp

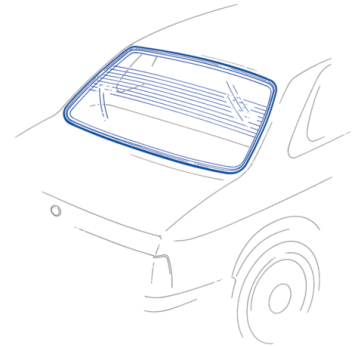

## STATIONARY SIDE GLASS (Doors, Quarter Panel, or Pillar)

### SPECIAL NOTATION:

Glass, moldings, mounting studs or mounting flange may be damaged or broken during normal service procedures on some applications. MOTOR advises that these factors be considered before performing glass operations in the event unavoidable damage occurs. Time for the removal of old urethane, clean and preparation of sealing surfaces (vehicle and/or glass) should be estimated after an on-the-spot evaluation.

### INCLUDED:

- Reveal & interior moldings/trim
- Rubber channel (if installed)
- Test for leaks
- Urethane adhesive application

### DOES NOT INCLUDE:

- Clean up of broken glass
- Cost of installation material or kit

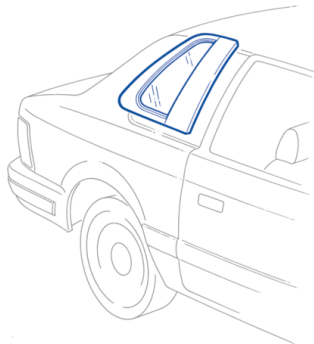

## DOOR - DOOR SHELL R&R, HINGED TYPE

### SPECIAL NOTATION:

Some replacement components may or may not be supplied with duplicated OEM caulk/seam sealer. This is not included in R&R time and requires an on-the-spot evaluation. Disconnect at hinges unless otherwise noted in text.

### INCLUDED:

- Align to vehicle
- Appliqué
- Belt Molding
- Bonded glass installation
- Door check
- Glass (fixed/moveable)
- Hinge halves bolted to door
- Inside handles & bezels
- Internal mechanisms
- Latch mechanisms
- License Lamp (if attached to door)
- License plate (if attached to door)
- Lock & cylinder assembly (if necessary)
- Mirror
- Outside handle
- R&I Door Module (if applicable)
- Regulator
- Speakers
- Trim panel R&I
- Vents
- Water shield
- Weatherstrips (if attached to door)
- Window/run channel

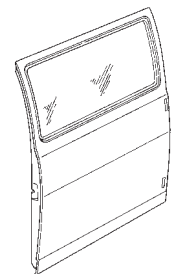
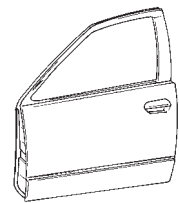

# GUIDE TO ESTIMATING

## DOOR - DOOR SHELL R&R, HINGED TYPE - Continued

### DOES NOT INCLUDE:

- Back glass wiper or washer
- Body side moldings
- Bonded glass removal from damaged door shell
- Emblems & nameplates
- Hinge halves bolted to pillar
- Hinge (welded type)
- Lock cylinder recoding
- Moldings
- Passive restraint system
- Power lock option
- Power window option
- Spare tire carrier
- Stripe tape, decals or overlays

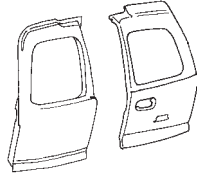

## DOOR-DOOR SHELL R&R, SLIDING TYPE

### SPECIAL NOTATION:

Some replacement components may or may not be supplied with duplicated OEM caulk/seam sealer. This is not included in R&R time and requires an on-the-spot evaluation. Disconnect at hinges unless otherwise noted in text.

### INCLUDED:

- Access cover
- Align to vehicle
- Appliqué
- Belt molding
- Bonded glass installation
- Glass (fixed/movable)
- Glass reveal moldings
- Inside handles and bezels
- Internal mechanisms
- Latch mechanisms
- Lock and cylinder assembly (if necessary)
- Outside handle
- R&I Door Module (if applicable)
- Regulator
- Speakers
- Trim panel R&I
- Vents
- Watershield
- Weatherstrips (if attached to door)
- Window/run channel

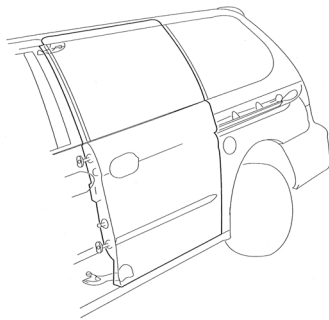

### DOES NOT INCLUDE:

- Body side moldings
- Bonded glass removal from damaged door shell
- Emblems and nameplates
- Lock cylinder recoding
- Moldings
- Stripe tape, decals or overlays

## DOOR - HINGED AND SLIDING TYPE OUTER PANEL R&R

### SPECIAL NOTATION:

Some cutting or welding processes may require the door glass to be removed prior to replacing outer panel. This factor should be considered prior to finalizing any repair cost estimates.

### INCLUDED:

- Adhesive application if required (all types)
- Appliqué
- Belt molding
- Caulk/seam sealer
- Cutting & welding as necessary
- Door R&I
- Flutter material application if required
- Grind, fill and smooth welded seams (up to 150 grit sandpaper)
- Inside handles & bezels
- Lock and cylinder assembly (if necessary)
- Mirror
- Outside door handle
- Speakers
- Trim panel R&I
- Water shield
- Weatherstrips (if attached to door)

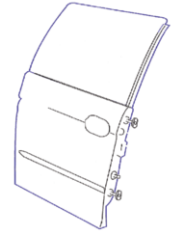

### DOES NOT INCLUDE:

- Back glass wiper or washer
- Body side moldings
- Clean up broken glass
- Emblems & nameplates
- Glass
- Hinge
- Lock cylinder recoding
- Moldings
- Passive restraint system
- Power lock option
- Power window option
- Regulator
- Reinforcement bar
- Straightening of door frame
- Stripe tape, decals or overlays

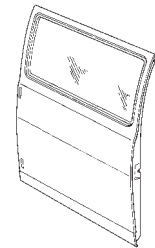

## ROCKER PANEL

### INCLUDED:

- Adhesive application if required (all types)
- Carpet & insulation turn back
- Caulk/seam sealer
- Cutting & welding as necessary
- Grind, fill & smooth welded seams (up to 150 grit sandpaper)
- Interior trim panels
- Sill plates
- Weatherstrips pull back

### DOES NOT INCLUDE:

- Carpet, insulation or seat R&I
- Control cables
- Door
- Emblems & nameplates
- Fender
- Foam
- Fuel lines

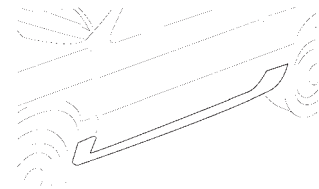



### ROCKER PANEL - Continued

- Moldings
- Stripe tape/decals

### CENTER PILLAR

#### SPECIAL NOTATION:

When replacing welded rear door hinges, add one-half of the Hinge R&R time to Center Pillar R&R time.

#### INCLUDED:

- Adhesive application if required (all types)
- Carpet & insulation turn back
- Caulk/seam sealer
- Cutting & welding as necessary
- Door striker
- Grind, fill & smooth welded seams (up to 150 grit sandpaper)
- Interior trim panels
- Seat belt anchor
- Sill plates
- Weatherstrips

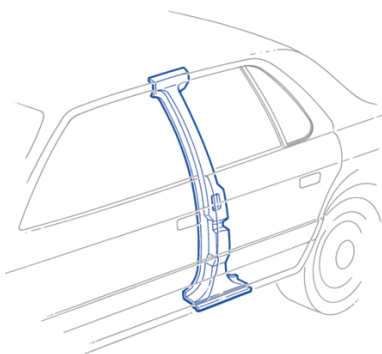

#### DOES NOT INCLUDE:

- Air bag components
- Carpet, insulation or seat R&I
- Doors
- Door hinge
- Electrical wiring
- Emblems & nameplates
- Foam
- Headliner
- Hinge plate transfer
- Lamp
- Moldings
- Roof cover
- Stripe tape, decals, or overlay

### UNISIDE/APERTURE PANEL WITHOUT QUARTER PANEL

#### SPECIAL NOTATION:

When replacing welded door hinges, add one half of the Door Hinge R&R time to Uniside R&R time. Included and Not Included items also apply to sectioning below roof (lower uniside) and sectioning roof rail (upper uniside). When sectioning other areas of uniside, follow GTE page for portion of uniside being sectioned.

### UNISIDE/APERTURE PANEL WITHOUT QUARTER PANEL - Continued

#### INCLUDED:

- Adhesive application if required (all types)
- Carpet & insulation turn back
- Caulk/seam sealer
- Center pillar trim (4 door models)
- Cutting and welding as necessary
- Door striker
- Front seat R&I
- Grind, fill & smooth welded seams (up to 150 grit sandpaper)
- Hinge pillar glass and moldings
- Hinge pillar trim
- Jamb switches
- Package tray trim
- Quarter panel trim
- Rear seat R&I
- Roof drip rail moldings
- Seat belt anchor
- Sill plates
- Weatherstrips

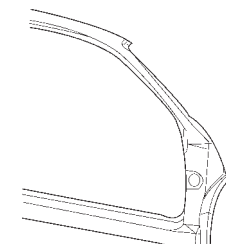
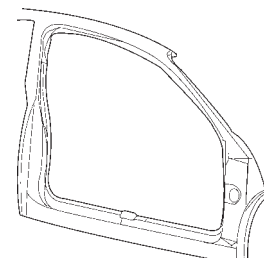
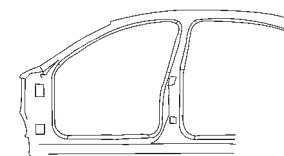
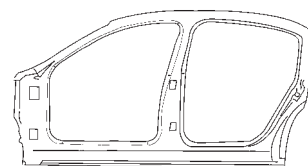

#### DOES NOT INCLUDE:

- Air bag components
- Back glass and moldings
- Carpet & insulation R&I
- Control cables
- Doors
- Door hinge
- Foam
- Electrical wiring
- Emblems & nameplates
- Fender
- Fluid lines
- Headliner
- Instrument panel
- Quarter glass and moldings
- Road wheel
- Roof cover
- Stripe tape, decals or overlay
- Windshield glass and moldings

# GUIDE TO ESTIMATING

## UNISIDE WITH QUARTER PANEL

### SPECIAL NOTATION:

When replacing welded door hinges, add one-half of the Door Hinge R&R time to Uniside R&R time.

Included and Not Included items also apply to sectioning below roof (lower uniside) and sectioning roof rail (upper uniside). When sectioning other areas of uniside, follow GTE page for portion of uniside being sectioned.

### INCLUDED:

- Adhesive application if required (all types)
- Back glass & moldings
- Carpet & insulation turn back
- Caulk/seam sealer
- Center pillar trim (four-door models)
- Cutting and welding as necessary
- Door striker
- Front seat R&I
- Fuel Door
- Grind, fill & smooth welded seams (up to 150 grit sandpaper)
- High-mounted stop lamp (if necessary)
- Hinge pillar glass and moldings
- Hinge pillar trim
- Jamb switches
- Package tray trim
- Quarter panel trim
- Quarter glass & moldings
- Rear bumper R&I
- Rear lamp
- Rear seat R&I
- Roof drip rail moldings
- Seat belt anchor
- Sill plates
- Trunk compartment trim
- Weatherstrips
- Wheelhouse liner (plastic)

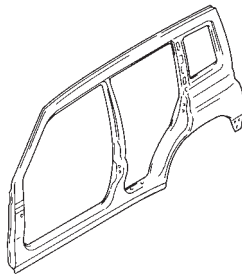
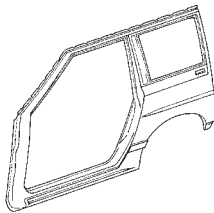
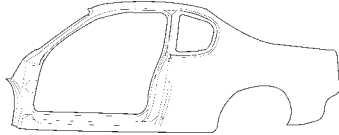

### DOES NOT INCLUDE:

- Air bag components
- Body side moldings
- Carpet & insulation R&I
- Control cables
- Doors
- Door hinge
- Electrical wiring
- Emblems & nameplates
- Fender
- Foam
- Fluid lines
- Headliner
- Instrument panel
- Road wheel
- Roof cover
- Stripe tape, decals or overlay
- Windshield glass and moldings

## QUARTER PANEL WITHOUT CONVERTIBLE ROOF

### SPECIAL NOTATION:

Quarter panel R&R times are generally based upon replacement at the factory seams. On some vehicles, it is not practical to replace at the factory roof seam. If a sectioning operation is not listed, then the R&R time on the parts line represents the time to splice at the best area. GTE page includes Quarter panel sectioning.

### INCLUDED:

- Adhesive application if required (all types)
- Back glass & moldings
- Bolt on extensions & fillers
- Carpet & insulation turn back
- Caulk/seam sealer
- Cutting & welding as necessary
- Door striker
- Fuel door
- Grind, fill & smooth welded seams (up to 150 grit sandpaper)
- Interior molding
- Quarter glass & reveal moldings (unless noted)
- Quarter interior trim
- Rear seat R&I
- Rear lamp assemblies R&I (std equip)
- Rear bumper assembly and/or cover R&I (if necessary)
- Rear package tray trim
- Sill plates
- Speakers
- Trunk compartment trim
- Weatherstrips attached to quarter panel
- Wheelhouse liner (plastic)

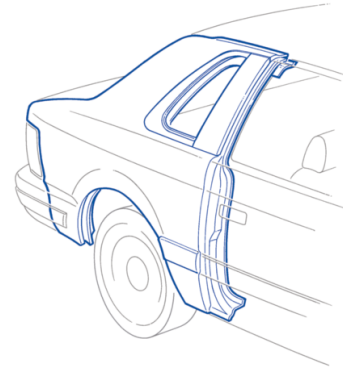

### DOES NOT INCLUDE:

- Antenna
- Body side moldings
- Carpet & insulation R&I
- Electrical wiring
- Emblems & nameplates
- Foam
- Fuel tank
- Glass regulator assembly
- Headliner R&I
- Lamp R&I (optnl equip)
- Mud guard
- Panels inward of quarter
- Road wheel
- Roof cover R&I or roll back
- Spoilers & flares (optnl equip)
- Stripe tape, decals or overlays
- Trunk lid, liftgate or tailgate R&I



# GUIDE TO ESTIMATING



## QUARTER PANEL - CONVERTIBLE ROOF MODELS

### INCLUDED:

- Adhesive application if required (all types)
- Belt moldings
- Bolt on extensions & fillers
- Carpet & insulation turn back
- Caulk/seam sealer
- Cutting & welding as necessary
- Door striker
- Fuel door
- Grind, fill & smooth welded seams (up to 150 grit sandpaper)
- Lamp
- Quarter glass & regulator assembly
- Quarter interior trim
- Rear lamp assemblies R&I
- Rear seat R&I (if necessary)
- Rear bumper assembly and/or cover R&I (if necessary)
- Sill plates
- Speakers
- Trunk compartment trim
- Weatherstrips attached to quarter panel, seal strip
- Wheelhouse liner (plastic)

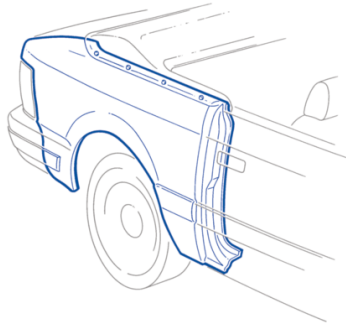

### DOES NOT INCLUDE:

- Antenna
- Body side moldings
- Boot well
- Carpet & insulation R&I
- Convertible top alignment
- Electrical wiring
- Emblems & nameplates
- Foam
- Fuel tank
- Mud guard
- Panels inward of quarter
- Power cylinder
- Retractable roof alignment
- Road wheel
- Roll bar
- Spoilers & flares
- Stripe tape, decals or overlays
- Trunk lid R&I

## TRUNK LID

### SPECIAL NOTATION:

Some replacement components may or may not be supplied with duplicated OEM caulk/seam sealer. This is not included in R&R time and requires an on-the-spot evaluation. Disconnect at hinge.

## TRUNK LID - Continued

### INCLUDED:

- Align to vehicle
- Appliqué panel
- Finish panel
- Finish plate
- Finish molding
- Finish trim
- Inside release
- Internal mechanisms
- Interior trim
- Latch or striker attached to lid
- License plate (if attached)
- License pocket
- Lock & cylinder assembly (if necessary)
- Trim moldings
- Lamps
- Weatherstrips (if attached to lid)

### DOES NOT INCLUDE:

- Camera
- Electrical wiring
- Emblems & nameplates
- Hinge
- Lock cylinder recoding
- Moldings (except as listed above)
- Spoilers & flares
- Stripe tape, decals or overlays

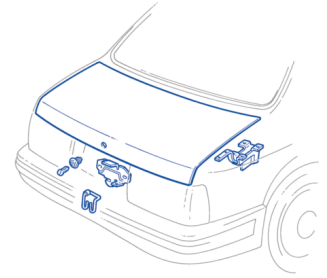

## LIFTGATE

### SPECIAL NOTATION:

Some replacement components may or may not be supplied with duplicated OEM caulk/seam sealer. This is not included in R&R time and requires an on-the-spot evaluation. Disconnect at hinge & support cylinder.

### INCLUDED:

- Align to vehicle
- Appliqué panel
- Bonded glass installation
- Glass (moveable)
- Glass moldings
- Finish panel
- Finish plate
- Finish molding
- Finish trim
- Inside release
- Interior trim
- Internal mechanisms
- Lamps
- Latch or striker attached to gate
- License plate (if attached)
- License pocket
- Lock & cylinder assembly (if necessary)
- Outside handle
- Trim moldings
- Trim panel R&I
- Watershield
- Weatherstrips (if attached to liftgate)
- Window/run channel

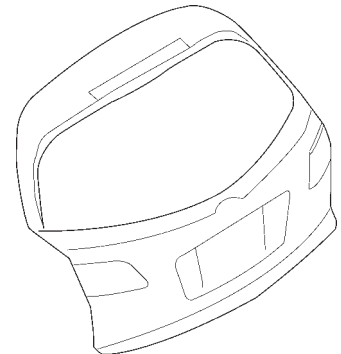



## LIFTGATE - Continued

### DOES NOT INCLUDE:

- Back glass wiper or washer
- Bonded glass removal from damaged liftgate
- Camera
- Electrical wiring
- Emblems & nameplates
- Hinges
- Lock cylinder recoding
- Moldings (except as listed above)
- Spare tire carrier
- Special interior trim
- Spoiler, flare or louver
- Stripe tape, decals or overlays

## TAILGATE - PASSENGER CARS/WAGONS

### SPECIAL NOTATION:

Some replacement components may or may not be supplied with duplicated OEM caulk/seam sealer. This is not included in R&R time and requires an on-the-spot evaluation.

Disconnect at hinge & support cylinder.

### INCLUDED:

- Align to vehicle
- Appliqué panel
- Bonded glass installation
- Glass (moveable)
- Finish panel
- Finish plate
- Finish molding
- Finish trim
- Inside release
- Internal mechanisms
- Interior trim
- Lamp
- Latch or striker attached to gate
- License plate (if attached)
- License pocket
- Lock & cylinder assembly (if necessary)
- Outside handle
- Regulator
- Run channel
- Trim panel R&I
- Water shield
- Weatherstrips (if attached to tailgate)
- Window/run channel

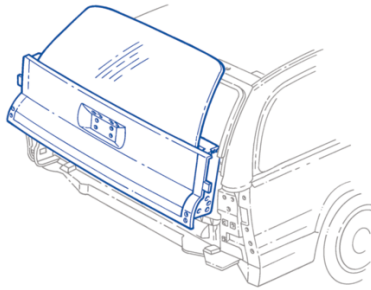

### DOES NOT INCLUDE:

- Back glass wiper or washer
- Bonded glass removal from damaged tailgate
- Camera
- Electrical wiring
- Emblems & nameplates
- Hinges
- Lock cylinder recoding
- Moldings (except as listed above)
- Spoiler, flare or louver
- Stripe tape, decals or overlays

## TAILGATE - OUTER PANEL R&R

### SPECIAL NOTATION:

Some cutting or welding processes may require the door glass to be removed prior to replacing the outer panel. This factor should be considered prior to finalizing any repair cost estimates.

### INCLUDED:

- Adhesive application if required (all types)
- Align to vehicle
- Appliqué panel
- Caulk/seam sealer
- Cutting & welding as necessary
- Finish panel
- Finish plate
- Finish molding
- Finish trim
- Flutter material application if required
- Grind, fill and smooth welded seams (up to 150 grit sandpaper)
- Interior trim
- Lamp
- License plate (if attached)
- License pocket
- Lock cylinder assembly (if necessary)
- Outside handle
- Tailgate R&I
- Trim panel R&I
- Water shield
- Weatherstrips (if attached)

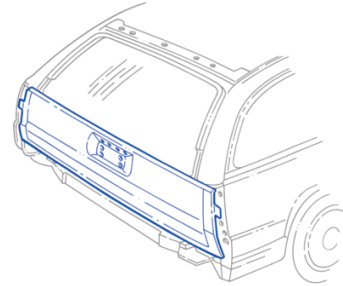

### DOES NOT INCLUDE:

- Back glass wiper or washer
- Bonded glass removal from damaged tailgate
- Camera
- Electrical wiring
- Emblems & nameplates
- Glass
- Hinge
- Moldings (except as listed above)
- Reinforcement bar
- Spare tire carrier
- Straightening of frame
- Stripe tape, decals or overlays

## REAR BODY - LOWER BODY PANEL

### INCLUDED:

- Adhesive application if required (all types)
- Bolt on extensions & fillers
- Bumper and/or cover assembly R&I
- Caulk/seam sealer
- Cutting & welding as necessary
- Grind, fill & smooth welded seams (up to 150 grit sandpaper)

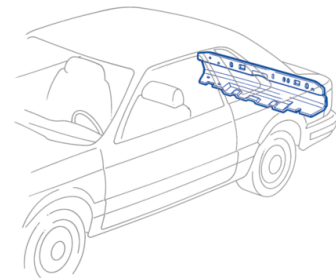



### REAR BODY - LOWER BODY PANEL -

#### Continued

- Lamp R&I
- Latch or striker
- License plate bracket
- License plate
- Rear compartment trim (as necessary)
- Sill plate
- Weatherstrips

#### DOES NOT INCLUDE:

- Camera
- Electrical wiring
- Fuel tank R&I
- Emblems & nameplates
- Energy absorber
- Exhaust system
- Lock cylinder recoding
- Moldings
- Stripe tape, decals or overlays
- Valance panel

### REAR BODY - FLOOR PAN/RAILS/ CROSSMEMBERS

#### INCLUDED:

- Adhesive application if required (all types)
- Cutting & welding as necessary
- Caulk/seam sealer
- Rear body panel (on floor pan only)

#### DOES NOT INCLUDE:

- Bolted-on parts
- Electrical wiring
- Exhaust system
- Rear body panel (on rails only)
- Sound-deadening pad

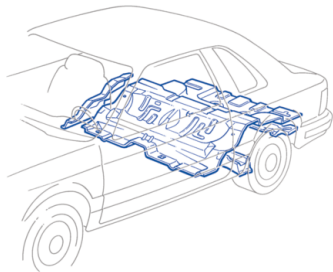

### FLOOR PAN - FRONT & CENTER FLOOR PAN

#### INCLUDED:

- Adhesive application if required (all types)
- Cutting & welding as necessary
- Caulk/seam sealer

#### DOES NOT INCLUDE:

- Bolted-on parts
- Electrical wiring
- Exhaust system
- Sound-deadening pad

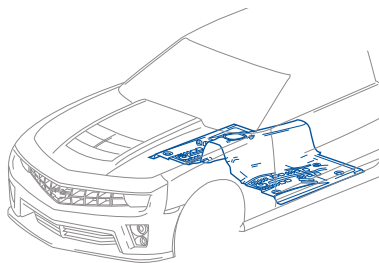

### FUEL TANK

**SPECIAL NOTATION:**  
Disconnect at fuel filler neck.

#### INCLUDED:

- Fuel pump (if necessary)
- Sending unit

#### DOES NOT INCLUDE:

- Exhaust system
- Fuel tank drain & refill
- Suspension & drivetrain R&I

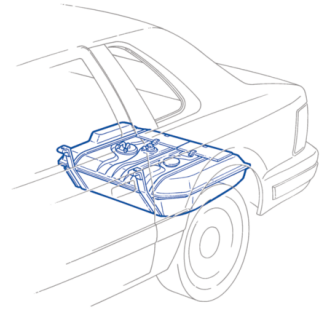

### REAR SUSPENSION - INDIVIDUAL OPERATIONS

#### INCLUDED:

- Raise & support vehicle (one time)

#### DOES NOT INCLUDE:

- Bolted-on parts
- Brake calipers R&I
- Brake shoes or pads
- Brakes adjust & bleed
- Road wheel
- Suspension/wheel alignment
- Wheel cylinders

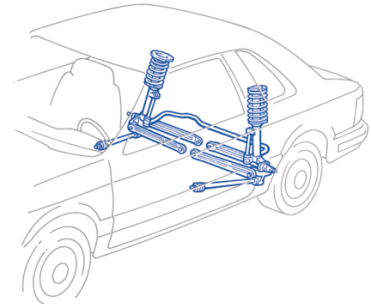

### REAR SUSPENSION - OVERHAUL STRUT TYPE

#### INCLUDED:

- ABS sensor
- Bearing seal R&R
- Bearing
- Brake drum/rotor
- Coil spring components
- Hub
- Knuckle
- Lower control arm
- Lower control arm bushing
- Overhaul procedure as defined
- Radius rod & bushing
- Raise & support vehicle (one time)
- Splash shield
- Stabilizer link
- Strut seat
- Strut radius rod & bushing
- Strut cartridge/assembly

#### DOES NOT INCLUDE:

- Axle or carrier assy
- Bolt-on crossmember
- Brake pad or shoes
- Brakes adjust & bleed

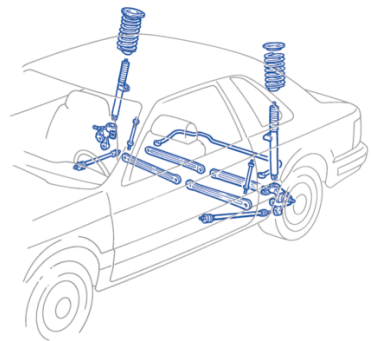

# GUIDE TO ESTIMATING

## REAR SUSPENSION - OVERHAUL STRUT TYPE - Continued

- Rear drive axle carrier/differential
- Road wheel
- Stabilizer bar
- Suspension/wheel alignment
- Wheel cylinders

## REAR SUSPENSION - OVERHAUL INDEPENDENT TYPE

### INCLUDED:

- ABS sensor
- Ball joint
- Bearing
- Bearing seal R&R
- Brake drum/rotor
- Coil spring components (if equipped)
- Hub
- Knuckle
- Lower control arm components
- Overhaul procedure as defined
- Radius rod & bushing
- Raise & support vehicle (one time)
- Shock absorber
- Splash shield
- Stabilizer link
- Strut
- Torsion bar (if equipped)
- Upper control arm components

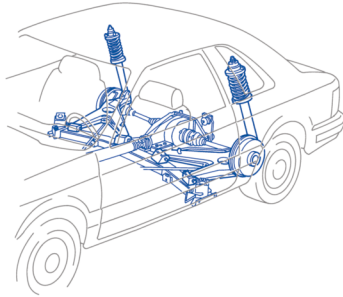

### DOES NOT INCLUDE:

- Axle or carrier assy
- Brake pad or shoe
- Brakes adjust & bleed
- Crossmember
- Road wheel
- Stabilizer bar
- Suspension/wheel alignment

## REAR SUSPENSION - OVERHAUL REAR TRAILING TYPE

### INCLUDED:

- ABS sensor
- Axle stub/spindle
- Axle beam
- Axle mounting pads
- Bearing
- Bearing seals R&R
- Brake rotor
- Coil spring or leaf spring components
- Control arms R&I
- Overhaul procedure as defined
- Radius rod & bushing
- Raise & support vehicle (one time)
- Shock absorber
- Splash shield
- Stabilizer link
- Strut

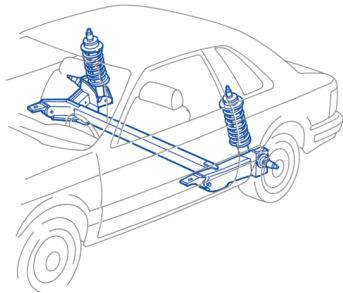

## REAR SUSPENSION - OVERHAUL REAR TRAILING TYPE - Continued

### DOES NOT INCLUDE:

- Axle or carrier assy
- Brake pad or shoes
- Brakes adjust & bleed
- Drive axles
- Road wheel
- Stabilizer bar
- Suspension/wheel alignment

## REAR BUMPER ASSEMBLY - R&I ALL TYPES

### INCLUDED:

- Align to vehicle

### DOES NOT INCLUDE:

- Emblems & nameplate
- Energy absorber, all types
- Molding & impact strip
- Stripe tape, decals or overlays
- Trunk trim/liner

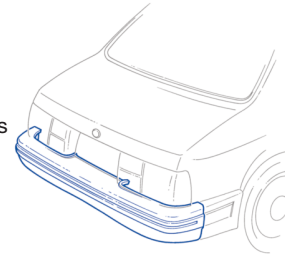

## REAR BUMPER ASSEMBLY - R&R FACE BAR TYPE

### INCLUDED:

- Align to vehicle
- Emblem & nameplate
- Face bar R&R
- Lamps (when mounted to bumper)
- License plate/bracket (if attached)
- Molding & impact strip

### DOES NOT INCLUDE:

- Energy absorber, if mounted to frame rail (all types)
- Lamps (optional equipment, or not mounted to bumper)
- Reverse sensor
- Stripe tape, decals or overlays
- Trunk trim/liner
- Valance panel/spoiler

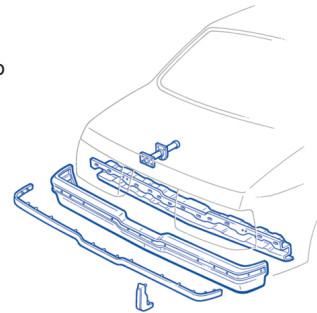

# GUIDE TO ESTIMATING



## REAR BUMPER ASSEMBLY – OVERHAUL FACE BAR TYPE

### INCLUDED:

- Align to vehicle
- Disassemble complete assembly
- Emblem & nameplate
- Lamp
- Lamps (when mounted to bumper)
- License plate/bracket (if attached)
- Molding & impact strip
- Reassemble complete assembly
- Reflectors
- Replace damaged parts

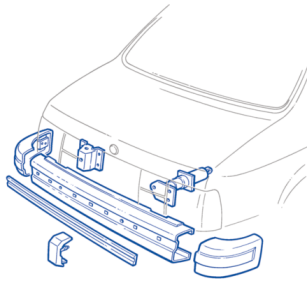

### DOES NOT INCLUDE:

- Energy absorber, if mounted to frame rail (all types)
- Lamps (optional equipment, or not mounted to bumper)
- Reverse sensor
- Stripe tape, decals or overlays
- Trunk trim/liner
- Valance panel/spoiler

## REAR BUMPER COVER – R&R COVER TYPE

### SPECIAL NOTATION:

The removal of mold-release agents from and preparation/priming of unprimed bumpers is required and is NOT INCLUDED. Where the OEM has provided information regarding the availability of unprimed bumper covers, an "Add if Required" labor operation has been added to the bumper group.

### INCLUDED:

- Align to vehicle
- Emblem & nameplate
- Energy absorber (when mounted to cover)
- Lamps (when mounted to bumper)
- License plate/bracket (if attached)
- Molding & impact strip
- Rear bumper cover
- Reflectors

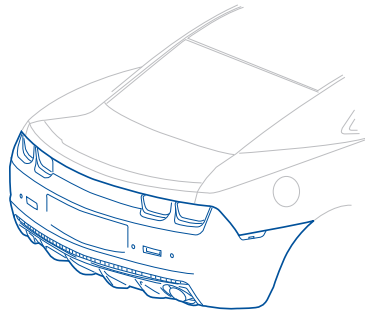

### DOES NOT INCLUDE:

- Bumper brackets/frame rail extensions (if mounted to frame rail)
- Lamps (optional equipment, or not mounted to bumper)
- Reinforcement/impact bar
- Reverse sensor
- Stripe tape, decals or overlays
- Trunk trim/liner
- Valance panel/spoiler

## REAR BUMPER COVER – OVERHAUL COVER TYPE

### SPECIAL NOTATION:

The removal of mold-release agents from and preparation/priming of unprimed bumpers is required and is NOT INCLUDED. Where the OEM has provided information regarding the availability of unprimed bumper covers, an "Add if Required" labor operation has been added to the bumper group.

### INCLUDED:

- Align to vehicle
- Disassemble cover assembly
- Emblem & nameplate
- Energy absorber (when mounted to cover)
- Lamps (when mounted to bumper)
- License plate/bracket (if attached)
- Molding & impact strip
- Reassemble complete assembly
- Reflectors
- Replace damaged parts

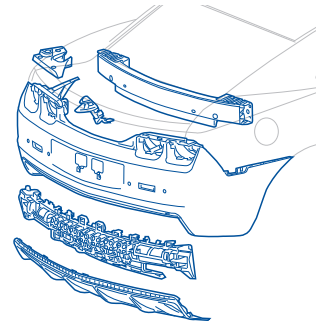

### DOES NOT INCLUDE:

- Bumper brackets/frame rail extensions (if mounted to frame)
- Lamps (optional equipment, or not mounted to bumper)
- Reinforcement/impact bar
- Reverse sensor
- Stripe tape, decals or overlays
- Trunk trim/liner
- Valance panel/spoiler

## PICKUP TRUCK – CAB ASSEMBLY, SKELETON

### INCLUDED:

- Bonded glass installation
- Cab R&R
- Carpeting
- Doors R&I
- Electrical wiring in cab R&I
- Glass (fixed/moveable)
- Headliner
- Instrument panel R&I
- Interior trim
- Interior mirror
- Reveal moldings
- Seats R&I
- Steering column R&I

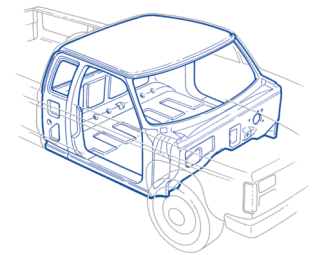

### DOES NOT INCLUDE:

- Body side molding
- Bonded glass removal from damaged cab
- Brackets & braces transfer
- Caulk/seam sealer
- Electrical wiring
- Emblems & nameplates
- Exterior lamps
- Foam
- Front end sheet metal
- Lock cylinder recoding
- Pickup box set back
- Stripe tape, decals or overlays
- Sun roof

# GUIDE TO ESTIMATING

## PICKUP TRUCK - UNISIDE WITHOUT SIDE OR CORNER PANEL

### SPECIAL NOTATION:

When replacing welded door hinges, add one half of the Door Hinge R&R time to Uniside R&R time.

### INCLUDED:

- Adhesive application (all types)
- Back panel trim
- Carpet & insulation turn back
- Caulk/seam sealer
- Center pillar trim (four-door models)
- Cutting and welding as necessary
- Door striker
- Front seat R&I
- Grind, fill & smooth welded seams (up to 150 grit sandpaper)
- Hinge pillar trim
- Jamb switches
- Rear seat R&I
- Roof drip rail moldings
- Seat belt anchor
- Side panel trim
- Sill plates
- Weatherstrips/windlace

### DOES NOT INCLUDE:

- Back glass and moldings
- Body side moldings
- Box set back
- Carpet & insulation R&I
- Control cables
- Doors
- Door hinge
- Electrical wiring
- Emblems & nameplates
- Fender
- Fluid lines
- Foam
- Instrument panel
- Road wheel
- Side glass & moldings
- Stripe tape, decals or overlay
- Windshield glass and moldings

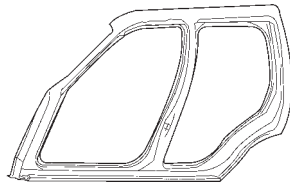
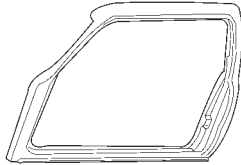
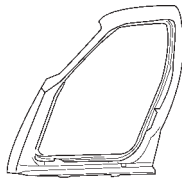

## PICKUP TRUCK - UNISIDE WITH SIDE OR CORNER PANEL

### SPECIAL NOTATION:

When replacing welded door hinges, add one half of the Door Hinge R&R time to Uniside R&R time.

### INCLUDED:

- Adhesive application if required (all types)
- Back glass and moldings
- Back panel trim
- Carpet & insulation turn back
- Caulk/seam sealer
- Center pillar trim (4 door models)
- Cutting and welding as necessary
- Door striker
- Front seat R&I
- Grind, fill & smooth welded seams (up to 150 grit sandpaper)
- Hinge pillar trim
- Jamb switches
- Rear seat R&I
- Seat belt anchor
- Side glass & moldings
- Side panel trim
- Sill plates
- Weatherstrips

### DOES NOT INCLUDE:

- Body side moldings
- Box set back
- Carpet & insulation R&I
- Control cables
- Doors
- Door hinge
- Electrical wiring
- Emblems & nameplates
- Fender
- Fluid lines
- Foam
- Headliner
- Instrument panel
- Road wheel
- Stripe tape, decals or overlay
- Windshield glass and moldings

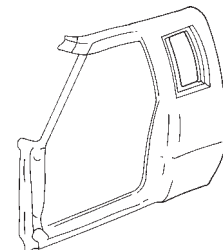
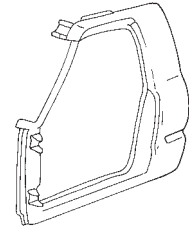

# GUIDE TO ESTIMATING



## PICKUP TRUCK - CAB SIDE/CORNER/BACK PANEL

### INCLUDED:

- Adhesive application if required (all types)
- Carpet & insulation turn back
- Caulk/seam sealer
- Cutting & welding as necessary
- Grind, fill & smooth welded seams (up to 150 grit sandpaper)
- Rear Seat R&I (extended or crew cabs)
- Seat R&I (regular cab)
- Side glass & moldings
- Sill plate
- Seatbelt anchor
- Shoulder harness
- Weatherstrips

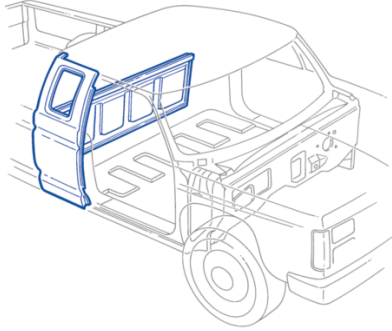

### DOES NOT INCLUDE:

- Back glass
- Body side moldings
- Box set back
- Carpet & insulation R&I
- Emblems & nameplates
- Exterior lamp
- Foam
- Headliner
- Interior trim
- Stripe tape, decals or overlays

## PICKUP TRUCK - BOX SET BACK

### SPECIAL NOTATION:

Pick-up box set back is considered by MOTOR to be the removal of the fasteners securing the box to the frame of the vehicle, D&R necessary wiring, D&R fuel neck and moving the box rearward. This operation is generally used for accessing the cab back or side panels or welds on the quarter panel.

### INCLUDED:

- Disconnect and move box rearward
- Move box forward and reconnect

### DOES NOT INCLUDE:

- Fuel tank
- Bumper R&I

## PICKUP TRUCK - BOX ASSEMBLY

### SPECIAL NOTATION:

Some replacement components may or may not be supplied with duplicated OEM caulk/seam sealer. This is not included in R&R time and requires an on-the-spot evaluation. Be sure to itemize both outside and inside panel refinish times when applicable.

### INCLUDED:

- Box R&R
- Bumper assembly R&I
- Fuel door
- Lamps
- License plate bracket
- Tailgate R&I
- Wheelhouse liner (plastic)

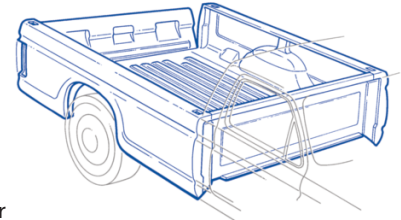

### DOES NOT INCLUDE:

- Accessory items
- Body side moldings
- Emblems & nameplates
- Fuel tank
- Mud flaps
- Stripe tape, decals or overlays

## PICKUP TRUCK - BOX FENDERS

### INCLUDED:

- Fender R&R
- Fuel door
- Lamp
- License plate bracket
- Wheelhouse liner (plastic)

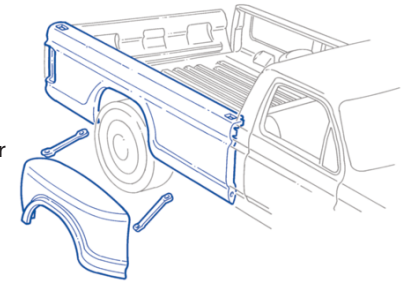

### DOES NOT INCLUDE:

- Body side moldings
- Emblems & nameplates
- Fuel tank
- Stripe tape, decals or overlays

# GUIDE TO ESTIMATING

## PICKUP TRUCK - BOX SIDE PANELS

### INCLUDED:

- Adhesive application if required (all types)
- Bolt-on extensions & fillers
- Bumper assembly R&I
- Caulk/seam sealer
- Cutting & welding as necessary
- Fuel door
- Grind, fill & smooth welded seams (up to 150 grit sandpaper)
- Lamp
- Tailgate R&I
- Wheelhouse liner (plastic)

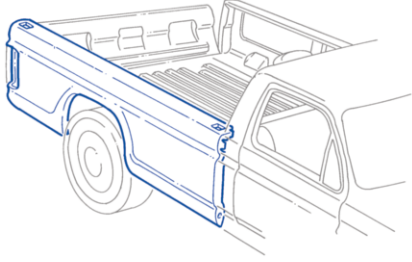

### DOES NOT INCLUDE:

- Body side moldings
- Box R&I
- Box set back
- Emblems & nameplates
- Front panel
- Fuel tank
- Outer fender
- Pickup box floor
- Standard running boards & step plates
- Stripe tape, decals or overlays
- Wheelhouse

## PICKUP TRUCK - BOX FRONT PANEL

### INCLUDED:

- Adhesive application if required (all types)
- Bolt on extensions & fillers
- Caulk/seam sealer
- Cutting & welding as necessary
- Grind, fill & smooth welded seams (up to 150 grit sandpaper)

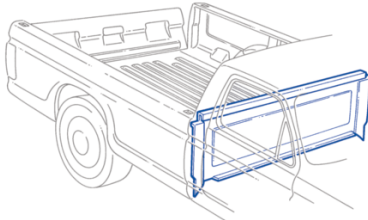

## PICKUP TRUCK - BOX FRONT PANEL - Continued

### DOES NOT INCLUDE:

- Body side moldings
- Box R&I
- Box set back
- Standard running boards & step plates
- Stripe tape, decals or overlays

## PICKUP TRUCK - BOX TAILGATE

### SPECIAL NOTATION:

Some replacement components may or may not be supplied with duplicated OEM caulk/seam sealer. This is not included in R&R time and requires an on-the-spot evaluation. Disconnect at hinge.

### INCLUDED:

- All bolted-on parts
- Hinge (bolted type)

### DOES NOT INCLUDE:

- Align to vehicle
- Body side moldings
- Emblems & nameplates
- Hinge (welded type)
- Stripe tape, decals or overlays

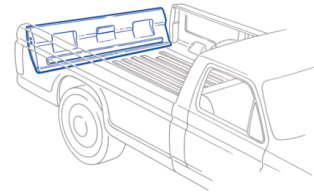

# GUIDE TO ESTIMATING



## VAN/SUV - SIDE AND CORNER PANELS

### SPECIAL NOTATION:

Side and corner panel R&R times are generally based upon replacement at the factory seams. On some vehicles, it is not practical to replace at the factory roof seam. If a sectioning operation is not listed, then the R&R time on the parts line represents the time to splice at the best area. When a sectioning operation time is listed, it represents the time to splice at the most efficient location, usually within the window openings. Both Full Panel R&R operations and Partial Panel Sectioning operations involve the same basic "INCLUDED" and "NOT INCLUDED" procedure steps.

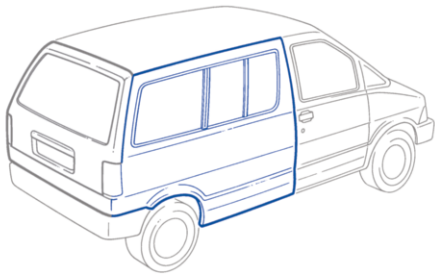
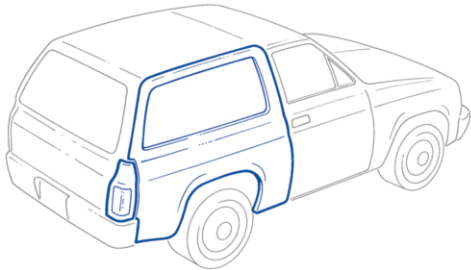

### INCLUDED:

- Adhesive application if required (all types)
- Bolt on extensions & fillers
- Bumper assembly R&I
- Carpet & insulation turn back
- Caulk/seam sealer
- Cutting & welding as necessary
- Detachable roof assemblies
- Door striker
- Fuel door
- Grind, fill & smooth welded seams (up to 150 grit sandpaper)
- Interior trim
- Lamp
- Side glass & moldings
- Sill plates
- Sliding door tracks (bolted)
- Weatherstrips & seals
- Wheelhouse liner

## VAN/SUV - SIDE AND CORNER PANELS - Continued

### DOES NOT INCLUDE:

- ABS sensor
- Air bag components
- Body side moldings
- Brackets, braces & supports transfer
- Carpet & insulation R&I
- Emblems & nameplates
- Exhaust system
- Floor
- Foam
- Fuel tank
- Headliner
- Mud guard
- Second row seats
- Sliding door tracks (welded)
- Spare tire carrier
- Stripe tape, decals or overlays
- SUV rear hinged door
- Tailgate/liftgate
- Third row seats
- Van sliding door
- Wheelhouse
- Window (aftermarket)

## REAR LAMPS

### SPECIAL NOTATION:

On some vehicles, the trunk compartment trim is partially pulled back rather than completely removed in order to access the rear lamp fasteners. MOTOR has taken this operation into consideration, and the partial pull back of trunk compartment trim is included in Rear Lamp R&R when applicable.

### INCLUDED:

- Access cover
- Bulb
- Trunk compartment trim (partial pull back if necessary)

### DOES NOT INCLUDE:

- Trunk compartment trim

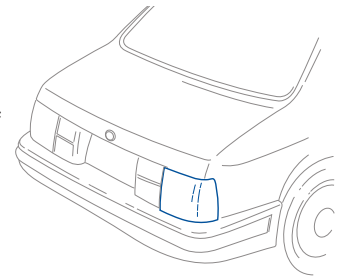



# GUIDE TO ESTIMATING

## DECALS, STRIPE TAPE & OVERLAYS

### INCLUDED:

- Clean/heat surfaces
- Component align/position
- Installation of component only

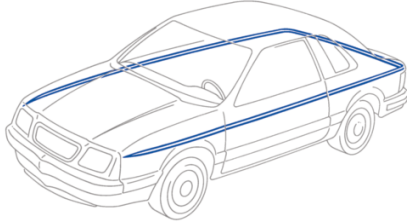

### DOES NOT

#### INCLUDE:

- Adhesive backing removal, clean up and replace
- Damage panel repair
- Door hardware

## ADHESIVE TYPE MOLDINGS, NAMEPLATES & EMBLEMS

### INCLUDED:

- Clean/heat surfaces
- Component align/position
- Installation of component only

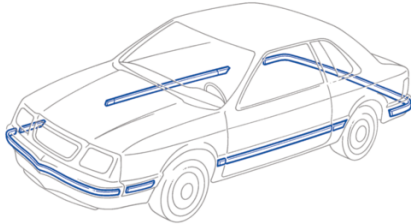

### DOES NOT INCLUDE:

- Adhesive backing removal, clean up and replace
- Damage panel repair
- Door hardware

## BOLT OR CLIP-ON MOLDINGS

### CONSIDERED:

- Drill time, if required
- If new parts are used on a new panel, add one half the replacement time
- If old parts are used on a new panel, add entire replacement time

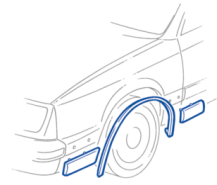

## DRILLING OPERATIONS

Service components may be inconsistently delivered by the manufacturer with mounting holes drilled at the factory. Drilling time should be added to the estimate if a component is received without mounting holes pre-drilled.

Time to drill holes is listed in parentheses next to the part description or in an “add if required” operation. For example, (d.2) indicates 0.2 for drilling. This time should be added to the estimate when it is determined a drilling operation is required. Time shown is for round holes only. Estimate time accordingly if holes must be a shape other than round.

### CONSIDERED:

- If new parts are used on a new panel, add drilling time and one half the replacement time
- If old parts are used on a new panel, add drilling time and entire replacement time



MOLDINGS, STRIPE TAPE & DRILL TIMES



### REFINISH TIME LISTINGS

All refinish times are listed in hours and tenths of an hour. A time in parentheses adjacent to the part name, such as (p3.5) indicates three and one half hours. Replacement operation time does not include time necessary to refinish the component.

Operation times for the application of painted-on stripes are not covered in this publication. The time necessary to perform this type of operation should be estimated after an on-the-spot evaluation of required procedure.

### REFINISH TIME PREMISE

Published refinish times are for one color applied to new undamaged replacement components, without exterior trim, interior trim or other attached components and applied in one continuous process. For damaged panel(s), published refinish times may be applied after the damaged panel has been returned to a NEW UNDAMAGED condition.

Refinish times do not include time which may be required to match color tints or defective finish textures on interior or exterior surfaces. Nor do they include time which may be required to correct finish imperfections caused by improper weather conditions, application, or environmental contamination such as dust, dirt, grease, etc. MOTOR advises all parties consider these factors beforehand to determine mutually acceptable provisions in the event such conditions exist or occur.

#### **ANTI-THEFT LABELS (R DOT)**

Replacement part labels are coded with the letter "R" to show that it is a replacement part. R Dot labels should not be removed from the part. Use caution when refinishing, rustproofing or undercoating replacement components to avoid damaging the label.

#### **BUMPER COVERS AND OTHER FLEXIBLE COMPONENTS**

Refinish times listed on the parts detail lines for these components are based on the items being refinished prior to installation. Refinish time listed on the parts detail line for an OEM bumper cover that has both body color and unpainted grained portion allows for the refinish of the body color only. Masking the grained, textured, or non-body color portions in preparation for body color application is an included operation. It includes exterior surface and edges refinished during one continuous process. If a separate edging procedure is utilized then the appropriate time should be estimated after an on-the-spot evaluation. Refinish times do not include removal of mold release agent from new unprimed molded components. Parts received from the OEM manufacturer without primer and some non-OEM parts with or without primer should be tested for the presence of release agents that would cause paint adhesion problems and treated accordingly. [An operation for the preparation of unprimed bumpers will be provided whenever such manufacturing information has been made available by the OEM. However, this information may not be available at the time of publication, and preparation for unprimed bumpers may still be required, even though a published operation is not present.](#) Preparation time for all unprimed components should be estimated after an on-the-spot evaluation. For unprimed component preparation time, see Unprimed Flexible Component Preparation on page G39. For unprimed bumper preparation time, see "Add If Required" operation(s).

#### **DOOR OUTER REPAIR PANELS**

Refinish times listed on the parts detail line for new repair panels (i.e. door outer repair panel, tailgate and liftgate repair panels) include panel lip. It does not include time for refinishing the entire door frame edge or interior side. Where possible, MOTOR will publish time for those areas under a "Refinishing Notes" heading within that group.

### REFINISH TIME PREMISE - Continued

#### **DOOR SHELLS, LIFTGATES AND TAILGATES**

Refinish times listed on the parts detail line for these new components include exterior surface, edges and interior sides, unless otherwise noted in text.

#### **DOOR SHELLS, LIFTGATES AND TAILGATES - Continued**

Refinish times listed under the "Refinishing Notes" heading for "door outer panel only" operations do not include time for refinishing the door frame edge or interior side. Where possible, MOTOR will publish time for those areas under a "Refinishing Notes" heading within that group.

#### **FENDERS, HOODS, TRUNK LIDS AND OTHER MAJOR BOLTED PANELS**

Refinish times listed on the parts detail line for these new panels do not include time for refinishing the edge or underside. Where possible, MOTOR will publish time for those areas under a "Refinishing Notes" heading within that group.

#### **QUARTER PANELS AND OTHER MAJOR WELDED PANELS**

Refinish times listed on the parts detail line for these new panels include exterior side, recessed edges, gutters and pockets, unless otherwise noted in text.

Refinish times listed under the "Refinishing Notes" heading for quarter panels or other major welded panels "exterior surface only" operations do not include time for refinishing recessed edges, gutters and pockets. Where possible, MOTOR will publish time for these areas under the "Refinishing Notes" heading within that group.

#### **NEW UNDAMAGED PANEL**

A component manufactured to the same exacting standards as the parts installed on new vehicles when the car was built. Exterior body panels are supplied with a smooth painted surface (e-coat).

#### **UNDERSIDE COLORS**

Refinish times presented in this guide are developed under the premise that the underside and jamb color is the same as the exterior body color. Some vehicle manufacturers use a different color for the engine compartment, trunk compartment and/or jambs. An additional paint mix is required if the underside and/or jamb color is a different color than the exterior body color. Clear coat (gloss or matte) will be required for base color coat applications. This should be considered when developing the estimate.

#### **PRIME & BLOCK**

Prime & block (high build/primer-filler) is a required procedure that restores a repaired panel surface, including the joined areas of replaced welded panels, from 150-grit finish to NEW UNDAMAGED condition. It is MOTOR's position that prime and block is a refinishing process best reserved for the judgment of an estimator/appraiser following a thorough on-the-spot evaluation of the specific vehicle and damage in question.

#### **REPAIRED PANEL REFINISHING**

MOTOR suggests using component(s) base refinish time for this type of procedure after the damaged panel is repaired to new undamaged condition. Repaired surface preparation requires an on-the-spot evaluation for additional procedural steps such as featheredge and/or prime and block not required for new undamaged panels.

## REFINISH TIME PREMISE - Continued

### PARTIAL PANEL REFINISHING

MOTOR defines partial panel refinishing as refinishing an area within a damaged body panel or underneath body cladding after the panel has been repaired to that of a "NEW UNDAMAGED PANEL," for the purpose of creating an undetectable color transition. The blend formula should NOT be used to determine refinish times for Partial Panel Refinishing.

It is MOTOR's position that partial panel refinishing is a process best reserved for the judgment of an estimator/appraiser following a thorough on-the-spot evaluation of the specific vehicle and refinish requirements in question. Refer to G.T.E. "BASIC COLOR COAT APPLICATION."

#### **SPECIAL NOTATION:**

**The items or operations below were not considered during the development of any published basic refinish operation times. These operations may or may not be required depending upon the vehicle or process used. If any of these items or operations are required, they should be considered by the estimator and added to the estimate if necessary.**

#### **REFINISH, WET/DRY SAND, DE-NIB and/or RUB-OUT TIME DOES NOT INCLUDE:**

- Anti-corrosion material application
- Filling, blocking, featheredging repaired panels
- Flex additive mixing time
- Flex prep application
- Material costs
- Mask inner panels ex: apron/cowl/pillars/rail/floor, etc.
- Molding & ornamentation
- Protective coating material application
- Protective coating removal
- Sound deadening application
- Spatter paint application time
- Stripe tape, decal & overlay
- Waste disposal fees (all types)

## PANEL and/or COMPONENT DESIGNATION

### MAJOR PANELS/COMPONENTS

All panels or components with a base refinish time of 1.0 hour or greater are generally considered by MOTOR to be major panels. Example: grille header panel, fender, hood, cowl top panel, doors, roof panel, rocker panel, quarter panel, engine lid, trunk lid, liftgate, rear gate, rear body panel, truck cab corner and back panel, truck bed front and side panel and van side and corner panels.

### MINOR PANELS/COMPONENTS

All panels or components with a base refinish time of less than 1.0 hour.

### FLEXIBLE PANELS/COMPONENTS

All panels or components for which paint systems require a flex agent added to the paint mix. Example: fascia covers, fillers, extensions, spoilers, etc.

No overlap deduction should be taken when calculating refinish time for a single item from this category.

A combination of items from this category refinished during a single, continuous procedure should be subject to the appropriate "Adjacent" or "Non-Adjacent" overlap formula deduction.

When a flex agent or a separate paint mix procedure is not required and when the flexible component is refinished during the same procedure with major or minor components, then flexible components should be considered the same designation as major or minor components for the purpose of calculating refinish overlap deductions and/or multi-stage refinishing additions.

## PANEL and/or COMPONENT DESIGNATION - Continued

### INDIVIDUAL PROCEDURE ITEMS/AREAS

Areas of a panel or component that are part of a main component, but are refinished during a procedure separate from the main component. Example: edges, jambs, hinges, inside panels and the underside of hoods, deck lids, liftgates, etc.

No overlap deduction should be taken when calculating refinish time for items from this category.

## DEDUCTIONS TO BASIC REFINISH TIMES (Refinish Overlap)

### OVERLAP – NON-ADJACENT PARTS:

- First major panel:
  - Use full published time
- Each additional part:
  - Deduct 0.2 per part

### OVERLAP – ADJACENT PARTS:

- First major panel:
  - Use full published time
- Each additional part with a base time of 1.0 hour or greater:
  - Deduct 0.4 per part
- Each additional part with a base time less than 1.0 hour:
  - Deduct 0.2 per part

### OVERLAP - INNER PANEL COMPONENTS:

- First inner part:
  - Use full published time
  - Each additional inner part with a base time of 0.5 hour or greater:
    - Deduct 0.2 per part
- Inner part with a base time less than 0.5 hour:
  - No deduct

## BASIC COLOR COAT APPLICATION

### INCLUDED:

- Back tape opening (handle, lock cylinder, mirror)
- Clean component (solvent wash)
- Clean sprayer
- Color coat application
- Initial dry sand (as recommended by paint manufacturer)
- Light buff, lacquer paint only
- Load sprayer
- Mask adjacent panels (three-foot perimeter)
- Mask/close gap between adjacent panels up to foam tape (overspray)
- Mask glass opening
- Mask/protect grille radiator opening (overspray)
- Mix paint (color with necessary solvents)
- Primer-sealer coat application
- Primer-sealer coat final clean
- Primer-sealer coat final application
- Remove masking
- Retrieve accurate color information, including paint chip

### DOES NOT INCLUDE:

- Adhesion promoter (unprimed flexible component)
- Backside refinishing
- Blending into adjacent panels

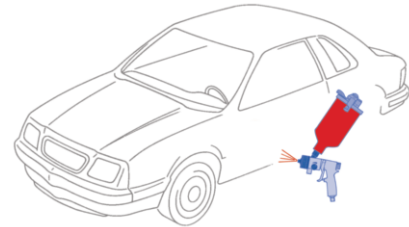



## BASIC COLOR COAT APPLICATION - Continued

### DOES NOT INCLUDE (continued):

- Cover mask engine/compartments to prevent overspray
- Color matching to adjacent panels
- Cover/mask for prime and block
- Cover/mask for cut-in
- Cover/mask recessed edges/jamb/weatherstrips
- Cover/mask trunk/compartments to prevent overspray
- Cover/mask entire exterior of vehicle to prevent overspray damage
- Cover/mask interior of vehicle to prevent overspray damage
- Edge refinishing
- Grind, fill, & smooth welded seams (up to 150 grit sandpaper)
- Paint or material costs
- Prime & block (high build/primer-filler)
- Test spray-out panel
- Tinting Primer-Sealer
- Tinting to achieve color match
- Underside refinishing
- Weld, grind or sanding damage to adjacent panels
- Wet sanding

## BAGGING (Cover Entire Vehicle Exterior)

Published refinish times include time necessary to mask exterior surface adjacent to the refinish area to a perimeter of 36 inches, or 3 feet. When the process of perimeter masking is substituted for an entire vehicle bagging procedure, then no additional time should be added. If entire vehicle bagging is used along with perimeter masking, then the following formula may be considered:

### APPLY AND REMOVE VEHICLE COVER (BAGGING)

- Add 0.2 each time a cover is applied and removed

## CLEAR COAT FINISHES (Base Coat/Clear Coat)

### SPECIAL NOTATION:

The following items or operations were not considered during the development of any published basic refinish operation times. If any of these items or operations are required, they should be considered by the estimator. Calculations should be made after deductions for overlap and additions for underside and edges, if required. It should be noted that it is not possible to sand, de-nib & polish, or rub-out and buff a matte clear finish, without changing the finish from matte to gloss. Therefore, a refinishing booth without airborne contaminants is required for this operation.

- First major panel:
  - Add 40% to refinish time
- Each additional panel:
  - Add 20% to refinish time
- Maximum time allocation:
  - 2.5 hours

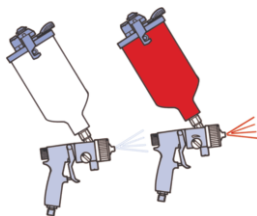

### INCLUDED:

- All components clear coated during a single, continuous procedure
- Apply clear coat
- Clean sprayer (one time)
- Mix clear coat (one time)
- Tack wipe surface (when required)

## CLEAR COAT FINISHES (Base Coat/Clear Coat) - Continued

### DOES NOT INCLUDE:

- Any component clear coated as a separate procedure
- Any operation previously excluded in "Refinish Time Premise" and/or "Basic Color Coat Applications" groups
- Material costs
- Texture matching (matte clear finishes)
- Test spray-out panel

## THREE-STAGE FINISHES (Base/Mica/Clear Coat)

### SPECIAL NOTATION:

The following items or operations were not considered during the development of any published basic refinish operation times. If any of these items or operations are required, they should be considered by the estimator. Calculations should be made after deduction for overlap and additions for underside and edges, if required (if three-stage finish from factory).

- First major panel:
  - Add 70% to refinish time
- Each additional panel:
  - Add 40% to refinish time

### INCLUDED

- Back tape opening (handle, lock cylinder, mirror)
- Mask/close gap between adjacent panels up to foam tape (overspray)
- Mask glass opening
- Mask/protect grille radiator opening (overspray)
- Retrieve accurate color information, including paint chip

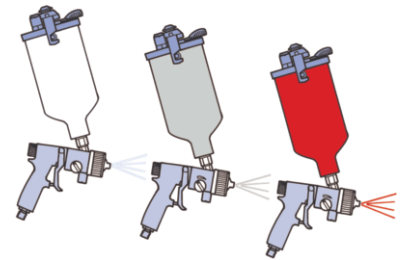

### DOES NOT INCLUDE

- Any component clear coated as a separate procedure
- Any operation previously excluded in "Refinish Time Premise" and/or "Basic Color Coat Application" groups
- Material costs
- Test spray-out panel
- Tint clear coat

## CLEAR COAT UNDAMAGED PANEL

### SPECIAL NOTATION:

Calculations for clear coating an undamaged panel are based upon the outer surface only and should not include additions for underside, inside or edges of the clear-coated panel. There should be no overlap deduction between refinished or clear-coated panel(s), nor should this procedure be applied towards the maximum clear coat allocation. Clear coating may be necessary for adjacent body panel(s) to nearest break point (see G 8). The following formula may be considered in the event this type of procedure is required on an undamaged panel:

- Each clear coated panel(s)
  - 40% of panel's Base Refinish Time

## CLEAR COAT UNDAMAGED PANEL - Continued

### INCLUDED:

- Back tape opening (handle, lock cylinder, mirror)
- Bonding/adhesion coat application (if required)
- Clear coat application
- Clean component (solvent/detergent wash)
- Clean in preparation for material application
- Initial wet sand or scuff
- Mask adjacent panels (three foot perimeter)
- Mask/close gap between adjacent panels up to foam tape (overspray)
- Mask glass opening
- Mask/protect grille radiator opening (overspray)
- Remove masking
- Tack wipe surface (when required)

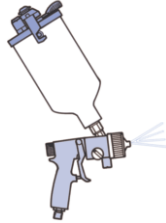

### DOES NOT INCLUDE:

- Correction of pre-existent surface imperfections
- Damage repair
- De-nib/wet sand and/or buff for polishing
- Masking of attached parts
- Material costs
- R&I of attached parts

## COLOR BLEND (Adjacent Panels)

### SPECIAL NOTATION:

Calculations for blending are based upon the outer surface only and should not include additions for underside, inside or edges of the blend panel. There should be no overlap deduction between blend panel(s) and/or refinished panel(s). This formula is not applicable to SINGLE-STAGE, 3-STAGE, 4-STAGE or TWO-TONE type finishes. Finishes of this type should be negotiated after an on-the-spot evaluation. Estimation of material cost should be based upon the full blended panel(s).

Blending may be necessary for adjacent body components to avoid noticeable color variation between newly applied paint and the existing paint of adjacent components or areas. The following formula may be considered in the event this type of procedure is required on an UNDAMAGED panel:

- Each blended adjacent panel or area  
– 50% of blend panel's base refinish time

### INCLUDED:

- Back tape opening (handle, lock cylinder, mirror)
- Blend coat application
- Bonding/adhesion coat application
- Clean component (solvent/detergent wash)
- Clean in preparation for material application
- Clear coat application (full blend panel if required)
- Initial wet sand or scuff (when required)
- Mask adjacent panels (three-foot perimeter)
- Mask/close gap between adjacent panels up to foam tape (overspray)
- Mask glass opening
- Mask/protect grille radiator opening (overspray)
- Remove masking

## COLOR BLEND (Adjacent Panels) - Continued

### DOES NOT INCLUDE:

- Correction of pre-existent surface imperfections
- Cover/mask recessed edges/jamb/weatherstrips
- Damage repair
- Masking of attached parts
- Material costs
- R&I of attached parts
- Wet sand and/or buff for polishing

## EDGES OF NEW PARTS (Edging)

### SPECIAL NOTATION:

The following items or operations were not considered during the development of any published basic refinish operation times. If any of these items or operations are required, they should be considered by the estimator. An additional paint mix is required if the edge color is a different color than the exterior body color. Clear coat (gloss or matte) will be required for base color coat applications.

### INCLUDED:

- Refer to specific parts text for estimated time allowance
- Use full refinishing time without deduction for overlap

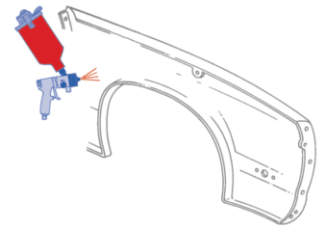

### DOES NOT INCLUDE:

- Clear coat
- Color tinting
- Mixing a different edge color

## THREE-STAGE COLOR BLEND (Adjacent Panels)

### SPECIAL NOTATION:

Calculations for blending are based upon the outer surface only and should not include additions for underside, inside or edges of the blend panel. There should be no overlap deductions between blend panel(s) refinish time. Blending may be necessary for adjacent body components to avoid noticeable color variation between newly applied paint and the existing paint of adjacent components or areas. The following formula may be considered in the event this type of procedure is required on an undamaged panel:

- Each blended adjacent panel or area  
70% of blend panel's base refinish time

### INCLUDED:

- Back tape opening (handle, lock cylinder, mirror)
- Blend coat application

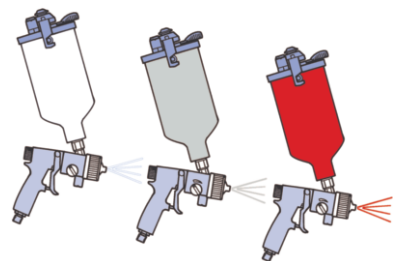



## THREE-STAGE COLOR BLEND (Adjacent Panels) - Continued

### INCLUDED (continued):

- Bonding/adhesion coat application
- Clean component (solvent/detergent wash)
- Clean in preparation for material application
- Clear coat application (full blend panel if required)
- Cover/mask recessed edges/jamb
- Panel preparation (when required)
- Mask adjacent panels (three-foot perimeter)
- Mask/close gap between adjacent panels up to front tape (overspray)
- Mask glass opening
- Mask/protect grille radiator opening (overspray)
- Remove masking

### DOES NOT INCLUDE:

- Correction of pre-existent surface imperfections
- Damage repair
- Masking of attached parts
- Material costs
- R&I of attached parts
- Wet sand and/or buff for polishing
- Test spray-out panel

## STONE CHIP GUARD (Protective Material)

### SPECIAL NOTATION:

The following items or operations were not considered during the development of any published basic refinish operation times. If any of these items or operations are required, they should be considered by the estimator.

- First panel:  
– Add 0.5 per panel
- Each additional panel:  
– Add 0.3 per panel

### INCLUDED:

- Up to a 12" height

### DOES NOT INCLUDE:

- Texture matching

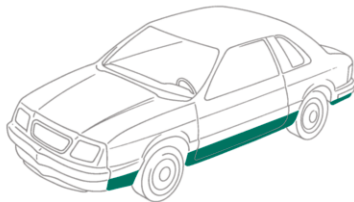

## TWO-TONE REFINISHING (Second Color Tone Application)

### SPECIAL NOTATION:

The following items or operations were not considered during the development of any published basic refinish operation times. If any of these items or operations are required on exterior, interior or undersides, they should be considered by the estimator. The following formula may be superseded by information published in specific parts text. Calculations should be made after deductions for overlap and additions for edges, if required.

- First panel:  
– Add 40% to refinish time
- Each additional panel:  
– Add 30% to refinish time

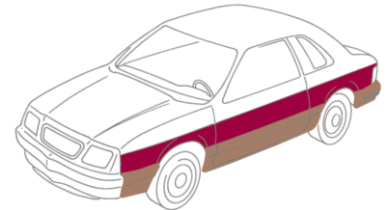

## UNDERSIDE OF HOODS, LIDS OR GATES

### SPECIAL NOTATION:

The following items or operations were not considered during the development of any published basic refinish operation times. If any of these items or operations are required, they should be considered by the estimator. An additional paint mix is required if the underside color is a different color than the exterior body color. Clear coat (gloss or matte) will be required for base color coat applications.

### INCLUDED:

- Refer to specific vehicle text for estimated time allowance
- Use full refinishing time without deduction for overlap

### DOES NOT INCLUDE:

- Clear coat
- Color tinting
- Mixing a different underside color

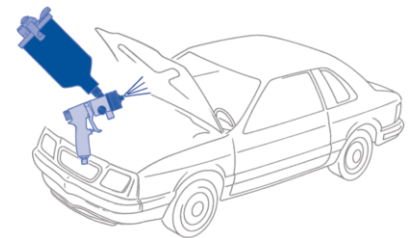

# GUIDE TO ESTIMATING

## WELD ZONE/ADJACENT PANEL

### SPECIAL NOTATION:

Suggested refinish operation times do not include additional time for repair of damage to adjacent panels resulting from normal cutting, welding and grinding procedures. The amount of damage can vary considerably depending upon process and technique used by the servicing technician and, therefore, is impractical to anticipate in this publication. MOTOR recommends these factors be considered before finalizing any repair cost estimate. Typical areas to be considered are illustrated below.

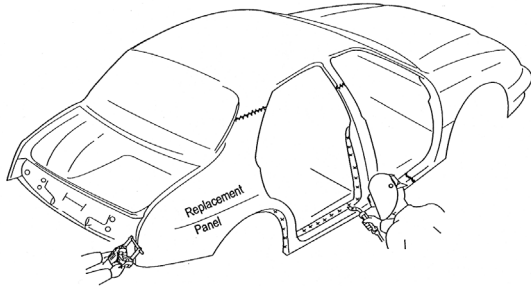

## DE-NIB & POLISH

### SPECIAL NOTATION:

Refinished panels may or may not require a varying amount of de-nibbing, a process used to remove small particles in final finish surface. The clear coat contains ultraviolet screeners and reducing the clear coat thickness (mils) may result in early paint failure. Follow vehicle manufacturer's recommendations when performing this type of repair. Calculations should be based upon the base refinish time outer surface only and should not include additions for clear coat, underside, inside or edges. In the event that this type of operation will be performed, MOTOR suggests the following formula be considered:

Each panel requiring de-nibbing (refinish or blend)  
*HOOD, ROOF, TRUNK LID, SPOILER*

First panel add up to 20% of full base refinish time,  
each additional panel add up to 10%

*FENDER, DOOR, QUARTER PANEL, BUMPER COVER*  
First panel add up to 10% of full base refinish time,  
each additional panel add up to 5%

### INCLUDED:

- Panel outer surface only
- Paint nib removal as required (spot only)
- Spot polish only

### DOES NOT INCLUDE:

- Acid rain damage
- Full panel polish
- Overspray removal
- Removal of residual material from recessed edges and jamps if required
- Scratch damage
- Wash, clean, wax or detail entire vehicle prior to delivery if required
- Wet sand full panel

## WET/DRY SAND, RUB-OUT & BUFF

### SPECIAL NOTATION:

Refinished panels may or may not require a varying amount of wet sanding, compound rub-out or buffing operations in order to match original finish texture. The clear coat contains ultraviolet screeners and reducing the clear coat thickness (mils) may result in early paint failure. Follow manufacturer's recommendations when performing this type of repair. Calculations should be based upon the outer surface only and should not include additions for clear coat, underside, inside or edges. Base refinish time does not include deduction for refinish overlap. In the event that this type of operation will be performed, MOTOR suggests the following formula be considered:

Refinished panels may or may not require a varying amount of wet sanding, compound rub-out or buffing operations. In the event this type of operation will be performed, MOTOR suggests the following formula be considered.

- Each panel requiring wet sand, rub-out and/or buff (refinish or blend)
  - Add 30% of full base refinish time

### INCLUDED:

- Panel outer surface only
- Wet sand full panel as required
- Compound, buff and/or polish as required

### DOES NOT INCLUDE:

- Acid rain damage
- Overspray removal
- Removal of residual material from recessed edges and jamps if required
- Wash, clean, wax or detail entire vehicle prior to delivery if required

## UNPRIMED FLEXIBLE COMPONENT PREPARATION

- 25% of the component's base refinish time
- Maximum time allocation: 1.0 hours

### INCLUDED:

- Removal of mold-release agents as outlined by manufacturer
- Masking (if required)
- Application of adhesion promoter

### DOES NOT INCLUDE:

- Correction of pre-existent surface imperfections
- Material Costs

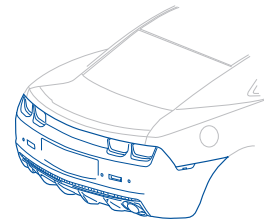

## Index

### TEXT EXPLANATION GUIDE . . . .G2

#### GENERAL INFORMATION

Bolted-On Parts . . . . .G3  
 Estimating Sequence . . . . .G3  
 Footnotes . . . . .G3  
 Part Prices . . . . .G3  
 Part Quantities . . . . .G3  
 Technical Information . . . . .G3  
 Underhood Diagrams . . . . .G4

#### INDUSTRY DEFINITIONS

Add If Required . . . . .G5  
 Component Classification . . . . .G5  
 D&R . . . . .G5  
 Frame Machine Set-Up . . . . .G5  
 Included and/or Not Included Operations . . . . .G5  
 NAGS . . . . .G5  
 O.E.M. . . . .G5  
 Overhaul . . . . .G5  
 Overlap . . . . .G5  
 R&I . . . . .G6  
 R&R . . . . .G6  
 Structural component identification . . . .G6

#### SPECIAL PRECAUTIONS

Acoustical And Structural  
     Foam Fillers . . . . .G7  
 Air Conditioner Refrigerant . . . . .G7  
 Damaged or Non-Reusable  
     Moldings and Fasteners . . . . .G7  
 Electronic Systems & On Board  
     Computers . . . . .G7  
 Hazardous Materials . . . . .G7  
 Hybrid/Electric Vehicles . . . . .G7  
 OEM Collision Repair Network . . . . .G7  
 OEM Component Replacement -  
     General . . . . .G7  
 Panel Bonding . . . . .G8  
 Parts Supplied In Color . . . . .G8  
 Refinish Clear Coat Application . . . . .G8  
 Restraint System (Air Bag) . . . . .G8  
 Restraint System (Seat Belt) . . . . .G8  
 Sectioning . . . . .G8  
 Special Substrates . . . . .G8  
 Steering Column . . . . .G9  
 Stone Chip Guard . . . . .G9  
 Structural Glass . . . . .G9  
 Welder Set-Up and Welding  
     Preparation . . . . .G9

#### LABOR PROCEDURES

Labor Time Listings . . . . .G10  
 Labor Time Premise . . . . .G10  
 Air Conditioner . . . . .G13  
 Brake (Bleed Hydraulic System) . . . . .G15

#### LABOR PROCEDURES (cont'd)

Bumper Assembly (Front) . . . . .G10, 11  
 Bumper Assembly (Rear) . . . . .G27, 28  
 Center Pillar . . . . .G22  
 Console Floor or Overhead . . . . .G19  
 Cowl, Hinge Pillar & Dash Panel . . . . .G18  
 Door - Door Shell . . . . .G20, 21  
 Door - Outer Panel . . . . .G21  
 Engine/Transaxle . . . . .G15  
 Fender - Front Rails . . . . .G15  
 Fender - Inner Panel . . . . .G14  
 Fender - Outer Panel . . . . .G14  
 Floor Pan - Front & Center Floor Pan .G26  
 Frame . . . . .G12  
 Front Lamps (Composite Type) . . . . .G14  
 Front Lamps (Sealed Beam Type) . . .G14  
 Fuel Tank . . . . .G26  
 Glass . . . . .G20  
 Grille . . . . .G13  
 Header Panel or Headlamp  
     Mounting Panel . . . . .G13  
 Heater . . . . .G13  
 Hood . . . . .G14  
 Instrument Panel . . . . .G18  
 Liftgate . . . . .G24  
 Pickup Truck: Box Assembly . . . . .G30  
     Box Fenders . . . . .G30  
     Box Front Panel . . . . .G31  
     Box Set Back . . . . .G30  
     Box Side Panels . . . . .G31  
     Box Tailgate . . . . .G31  
     Cab Assembly, Skeleton . . . . .G28  
     Cab Side/Corner/Back Panel . . . .G30  
     Roof . . . . .G19  
     Unside . . . . .G29  
 Quarter Panel:  
     Convertible Roof Models . . . . .G24  
     w/o Convertible Roof . . . . .G23  
 Radiator . . . . .G13  
 Radiator Support . . . . .G13  
 Rear Body - Floor Pan/Rails . . . . .G26  
 Rear Body - Lower Body Panel . . . .G25  
 Rear Lamps . . . . .G32  
 Road Wheel . . . . .G15  
 Rocker Panel . . . . .G21  
 Roof . . . . .G19  
 Roof Headliner . . . . .G19  
 Steering . . . . .G17  
 Suspension (Front) . . . . .G16, 17  
 Suspension (Rear) . . . . .G26, 27  
 Tailgate - Passenger  
     Cars/Wagons . . . . .G25  
 Tailgate - Outer Panel . . . . .G25  
 Trunk Lid . . . . .G24  
 Unside with Quarter Panel . . . . .G23  
 Unside without Quarter Panel . . . .G22  
 Valance Panel . . . . .G11  
 Van/Truck/SUV: Liftgate  
     Roof . . . . .G19  
     Side & Corner Panels . . . . .G32

#### LABOR PROCEDURES (cont'd)

Wheel Alignment . . . . .G17, 18

#### MOLDINGS, STRIPE TAPE & DRILL TIMES

Decals . . . . .G33  
 Drilling Operation . . . . .G33  
 Moldings - Bolt or Clip on Type . . . .G33  
 Moldings, Nameplates &  
     Emblems - Adhesive Type . . . . .G33  
 Overlays . . . . .G33  
 Stripe Tapes . . . . .G33

#### REFINISHING PROCEDURES

Bagging (Cover Entire Vehicle) . . . . .G36  
 Basic Color Coat Application . . . . .G35  
 Clear Coat Finishes . . . . .G36  
 Clear Coat Undamaged Panel . . . . .G36  
 Color Blend . . . . .G37  
 De-Nib & Polish . . . . .G39  
 Edges of New Parts . . . . .G37  
 Panel and/or Component  
     Designation . . . . .G35  
 Refinish Overlap . . . . .G35  
 Refinish Time Listings . . . . .G34  
 Refinish Time Premise . . . . .G34  
 Stone Chip (Protective Material) . . . .G38  
 Three-Stage Color Blend . . . . .G37  
 Three-Stage Finishes . . . . .G36  
 Two-Tone Refinishing . . . . .G38  
 Undersides of Hoods, Lids  
     or Gates . . . . .G38  
 Unprimed Bumper Preparation . . . . .G39  
 Weld Zone/Adjacent Panel . . . . .G39  
 Wet Sand, Rub-Out & Buff . . . . .G39